



CONSTRUCTION EQUIPMENTS ASSEMBLY SOLUTIONS

BUILDING TRUST



ADHESIVE SOLUTIONS FOR CONSTRUCTION EQUIPMENTS PRODUCTION

When a structural bond is needed, Sika's technologies provide the right answer. Our products are suitable to bond the most common substrates used in industrial applications. For years, construction equipment manufacturers have been relying on Sika solutions to bond metal housing of all types of equipment. Sikaflex® and SikaForce® fully meet these requirements, providing a structural, weatherproof and vibration damping joint that can be overpainted.

ADVANTAGES

- Modern look and a smooth surface without screws or rivets
- Material savings due to the potential use of thinner metal sheets
- No corrosion caused by screw and rivet holes
- Damping of vibrations and noise due to the elastic properties of Sikaflex®-552 and Sikaflex®-953

PRODUCT FEATURES

- Structural bond
- Weatherproof
- Suitable for a wide range of substrates
- Optimized for large and small scale industrial applications
- Gap filling and fast handling properties with Sikaflex®-953 and SikaForce®-7888 thanks to the 2-component technology

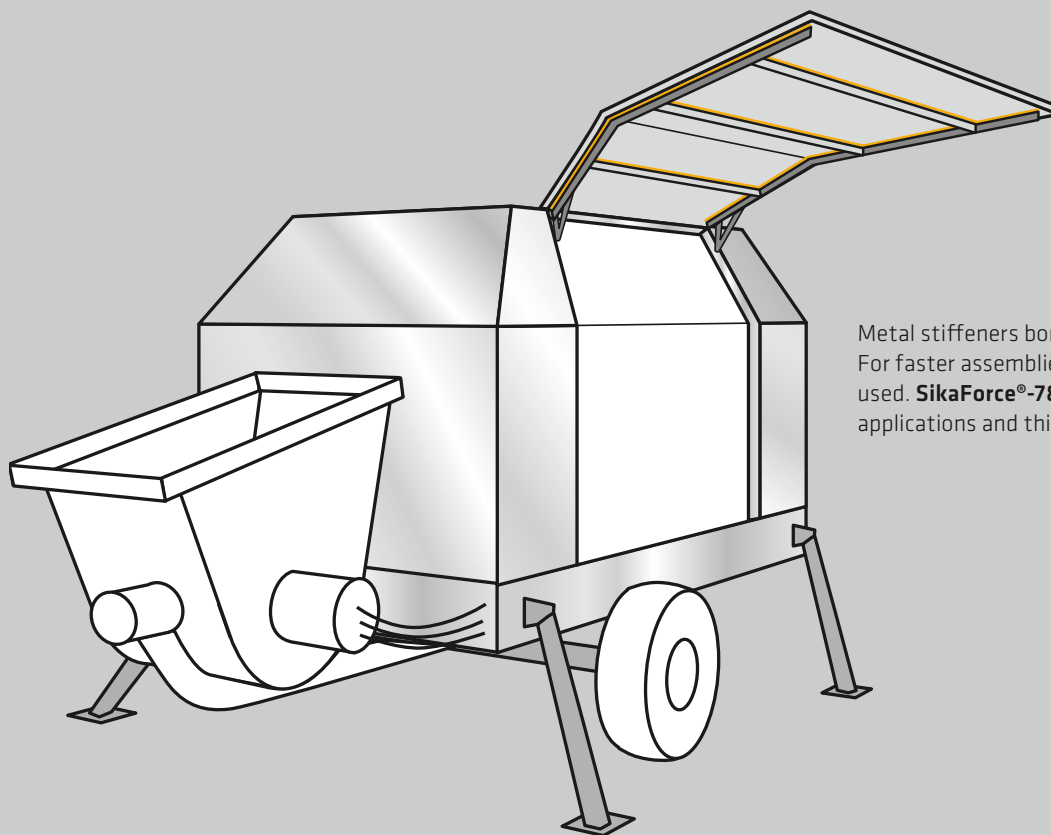

Metal stiffeners bonded with **Sikaflex®-552 AT**. For faster assemblies, **Sikaflex®-953** can be used. **SikaForce®-7888** is suitable for high load applications and thick metal sheets.

SIKA SERVICES AG

Tueffenwies 16
CH-8048 Zurich
Phone: +41 (0) 58 436 40 40
Fax: +41 (0) 58 436 55 30
www.sika.com/appliances

Our most current General Sales Conditions shall apply.
Please consult the Data Sheet prior to any use and processing.



BUILDING TRUST

