



SIKA FACADE SYSTEMS SEALING AND BONDING IN FACADES - SPECIFICATION GUIDE



CONTENTS

04 INTRODUCTION

06 FACADE TECHNOLOGIES

08 STRUCTURAL GLAZING

- 10 FACADE SYSTEM COMPONENTS – GLASS AND METAL FRAME
 - 11 Sikasil® SILICONE SEALANTS IN DETAIL
 - 12 ONE-PART VS. TWO-PART SILICONES
 - 13 MECHANICAL PROPERTIES
 - 14 BEHAVIOR AND RESISTANCE
 - 16 Sikasil® SG SILICONE ADHESIVES
 - 18 JOINT DESIGN
 - 19 CALCULATING JOINT BITE
 - 20 CALCULATING JOINT THICKNESS
 - 22 ULTIMATE SAVINGS BY STRENGTH
Sikasil® SG-550, Sikasil® IG-25 HM Plus
-

24 INSULATING GLAZING

- 26 Sikasil® IG SECONDARY SEALANTS
 - 27 Sikasil® IG-25 HM Plus – ENERGY-SAVING WITH INERT GAS FILLING
 - 28 SEAL HEIGHT CALCULATION
 - 29 EFFECT OF ENVIRONMENTAL LOADS
-

30 WS WEATHERSEALS

- 30 SikaHyflex® WEATHERSEALS
 - 32 NATURAL STONE SEALING
 - 34 FIRE-RATED SEALING
-

35 ANCILLARY PRODUCTS

36 SIKAMEMBRAN® SYSTEM

- 36 SikaMembran® SYSTEM – PERFECT VAPOR PROOFING IN ALL CLIMATES
 - 38 SikaTack® Panel SYSTEM – RAIN SCREEN CLADDING
 - 39 SikaDamp® – NOISE REDUCTION IN PANEL WALLS
 - 40 SikaGlaze® GG GLASS GROUT – STRESS FREE GLASS EMBEDDING
-

42 PROJECT SERVICE

- 43 SYSTEMATIC PROJECT WORKFLOW
 - 44 TRIPLE-TESTED QUALITY
 - 45 PROJECT TESTS
 - 46 SUPPORT BEYOND STANDARDS
-

left:

The Shard, London, 2013
Architects Renzo Piano Building Workshop
Facade Scheldebouw (UK)

INTRODUCTION

High-tech Solutions for Perfect Facades

ARCHITECTURE THRIVES ON CHANGE. On creative ideas and bold solutions that fascinate and surprise us every time. Curtain walls are a particularly severe challenge for planners, because they not only set the character of the structure but must also meet stringent requirements.

CREATIVE FACADE ARCHITECTURE

To strike the ideal balance between aesthetic appeal and energy efficiency, architects are increasingly turning to glass for curtain wall construction. As transparent structural glazing walls, single, double or triple glazed or even double skin facades. Glass can also be combined with other materials such as natural stone, metals or plastic coated metals, giving planners a wide scope for creativity.

But an immaculate optical appearance isn't the only crucial factor. Facades and windows must provide long-term durable systems. This requires perfect adhesion between the components and highly elastic, weatherproof seals. These specifications call for high-tech silicone sealants, which are tailored to meet highly specific demands and guarantee peak performance in every respect. With this application in mind, Sika supplies a wide range of tried-and-tested, innovative facade products for every demand:

Sikasil® and SikaHyflex®. Each of these sealants and adhesives has highly specific properties that are precisely tailored to the particular application. From structural glazing and insulating glass secondary seals through to weatherseals.

SikaMembran® membrane systems supplement ideally the sealants range for water/ vapor proofing wide joints in both curtain wall and ventilated facades.

The self-leveling PU grout SikaGlaze® GG is an easy-to-apply product for stress-free embedding of glass balustrades and glass walls in fin glazing.

Find more solutions for curtain wall facades on pages 36 to 40 and in our brochure Sika – Sealing and bonding in facade and fenestration.

CREATIVE DESIGN, CHALLENGING LOADS, INNOVATIVE MATERIALS

Sika has the right solutions

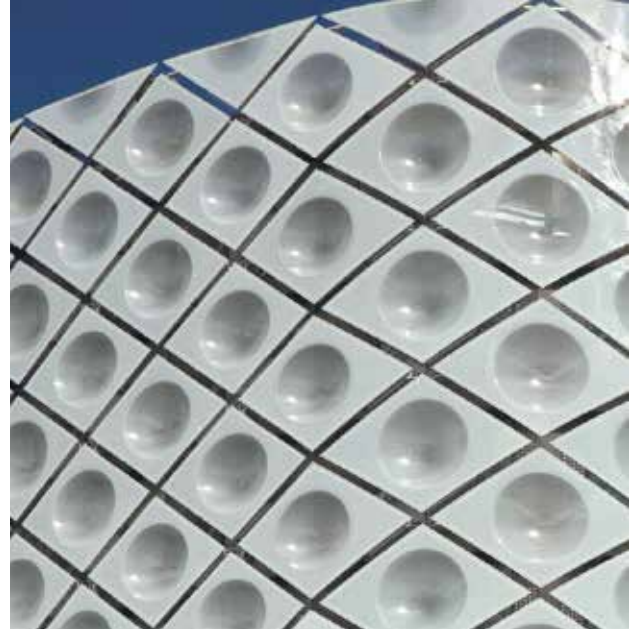
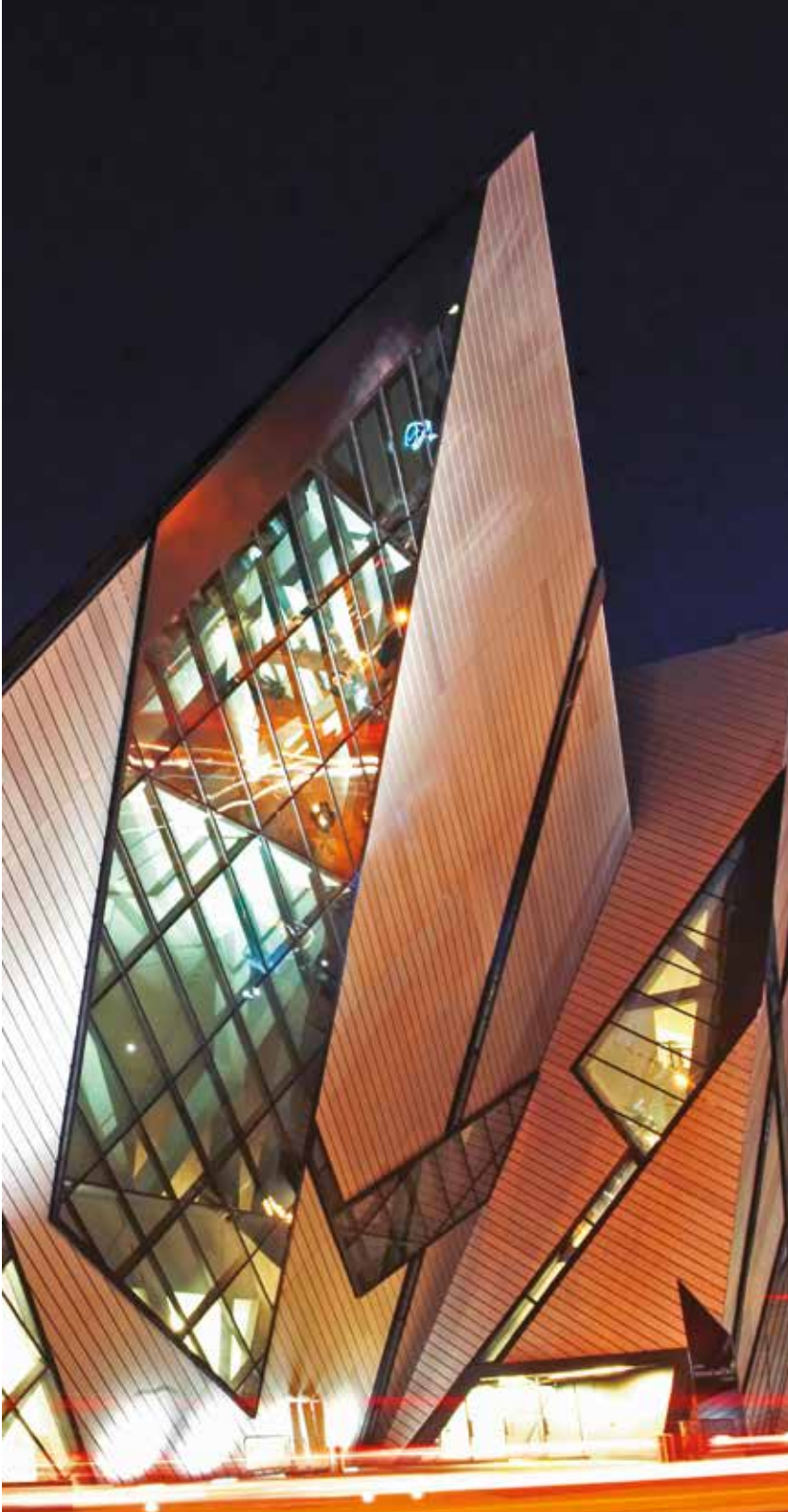

top right and cover:
Hospital Rey Juan Carlos, Madrid, 2012
Architects Rafael De La-Hoz
Facade Permasteelisa Spain
Curved Glass Cricursa

bottom right:
National Swimming Center (Water Cube), Beijing, 2008
Architects State Construction Engineering Corp., PTW Architects
Facade Shenyang YuanDa

left:
Royal Ontario Museum, Toronto, 2007
Extension Michael Lee-Chin Crystal
Architects Studio Daniel Libeskind
Facade Josef Gartner

FACADE TECHNOLOGIES

Durable Solutions for Every Design

STRUCTURAL GLAZING SYSTEMS can be either two-sided or four-sided, with each design having its own particular advantages. In general, for efficient and energy-saving building management, double and triple glazing is recommended.

1 Optimum Transparency



FOUR-SIDED STRUCTURAL GLAZING

Frameless Appearance

Four-sided structural glazing is impressive first and foremost because of its monolithic frameless appearance. All four sides of the large-format pane element are bonded to an adapter profile with Sikasil® SG silicone adhesive sealants and have no visible frame. These prefabricated glass modules are subsequently attached to the support structure so that the facade gives the appearance of a flat glass surface. The dynamic loads are transmitted through the silicone adhesive. To support the dead load of the glass, we recommend a mechanical support that is not visible from the outside.

Advantages of this System

- Attractive appearance without visible frames
- Thanks to its high elasticity, the silicone sealant can transmit the loads at all four sides more efficiently and uniformly
- Temperature distribution in the glass is ideal, since there are no cap profiles, which would act as shades. This reduces the risk of glass breakage caused by thermal stresses
- The facade is more energy-efficient as there are no external metal parts and all joints are sealed
- Greater self-cleaning from level glass

2 Optimum Safety



TWO-SIDED STRUCTURAL GLAZING

Mechanical Fixing

In the two-sided structural glazing system, only two mutually opposite glass or panel edges are bonded (horizontally or vertically) to a frame with Sikasil® SG silicone adhesive. The two other mutually opposite sides are fixed mechanically like capped CW systems. Mechanical fixing of the glass element at two sides does not affect the loads on the two bonded sides. Since excessive bending of the glass must be prevented, the minimum dimensions of the joint must not be changed compared to a four-sided system.

Advantages of this System

- High mechanical safety
- The silicone adhesive and the mechanical fasteners help distribute the dynamic forces
- Metal cap profiles can be used as design elements to make the facade seem less severe

For structural glazing silicone adhesive sealants Sikasil® SG see page 16.

3 The Lightness of Glazing



POINT-FIXED GLAZING

Maximal transparency

In point-fixed glazing systems, the glass elements are fixed to cable systems or metal beams by metal fasteners. These fasteners are embedded in holes in the glass pane with “glass cement” or a plastic jacket. Alternatively they can be bonded to the glass with high-strength silicone adhesives. The glasses can be single panes (e.g. laminated glass in the outer skin of the double skin facade) or insulating units with UV-resistant silicone edge sealing and even with argon filling (Sikasil® IG). SikaHyflex® with their high movement capability are a suitable weathersealants for the joints between the glass elements.

Advantages of this System

- High mechanical safety
- Lightweight glass constructions feasible

For the embedding of the metal fasteners into the glass holes and perfect leveling of production tolerances please ask for the Sika® AnchorFix® series.

For UV-resistant weather sealing between the glass panes with SikaHyflex® silicones see page 30.

4 Slim and Energy Efficient Design



STRUCTURAL WINDOW BONDING

Glass Carries the Frame

In bonded windows the IG units are structurally bonded to the sash frame. The loads are uniformly transferred to the sash. Thus peak stresses are minimized. Architects appreciate the resulting slim sash frames. In conjunction with the superior thermal and sound insulation this makes a compelling argument for the entire design team. Owners are equally delighted by the long service life and minimal maintenance requirement for structurally bonded windows.

Advantages of this System

- Slim sash design and low frame factor
- Up to 30 % more light
- Improvement of thermal and sound insulation
- Increase of approved wind load
- Reduction of production and service costs
- Up to 90 % lower complaint rate

For details of window bonding see www.sika.com/windows

STRUCTURAL GLAZING

Sophisticated Architecture and Innovative Technology

STRUCTURAL GLAZING MODULES are subject to extremely high stresses. They must accommodate wind and snow loads as well as thermal expansion, and permanently transfer the forces to the support structure, while also withstanding weathering over many years.

DURABLE CONSTRUCTION

Sikasil® SG silicone adhesive sealants are used in structural glazing for bonding the glass elements to the metal support frames. The elements may be designed as single glazing or insulating glazing to provide an insulating facade, which forms the complete building envelope and guarantees excellent corrosion protection. Coated multifunctional insulating glazing provides the necessary protection against the sun. Other variants include double skin facades produced with single glazing elements. The elastic joints produced with Sikasil® SG silicone adhesives accommodate movements of the construction elements resulting from temperature changes, moisture, shrinkage of construction materials, sound, wind and vibrations. Permanently.

ECONOMICAL CONSTRUCTION

Structural glazing facades have both technical and economical advantages:

- The factory-produced units can be installed quickly and economically (unitized glazing)
- An efficient insulating facade slashes thermal losses, providing a much improved energy balance
- High solar heat recovery can be taken into account in the energy balance
- Acoustic insulation is improved by insulating glazing and elastic silicone sealant
- These easy-to-clean facades have low maintenance and cleaning costs
- Repairs can be carried out much more economically by quick and easy module exchange

INTEGRATED SYSTEMS

A fully integrated structural glazing system is only possible if a number of conditions are met:

- Project-specific computation of the joint dimensions so that the system can be perfectly executed down to the last detail
- Factory bonding of the industrially manufactured glass modules with extreme positional accuracy
- Frame construction exactly tailored to the type of facade
- Sealants and weatherseal gaskets of compatible high-quality materials, which meet the strictest construction regulations and international standards
- Stringent quality control on all the products used, from production through to application



Menara Bank Islam (Menara Wakaf), Kuala Lumpur, 2001
Architects RSP Architects
Facade Puspajaya Aluminium

STRUCTURAL GLAZING – THE PRINCIPLE

The illustration shows a structural glazing module prototype. This drawing is not intended as a construction guide. More elaborate, additional structural elements may be needed to satisfy national construction regulations or project-specific requirements.

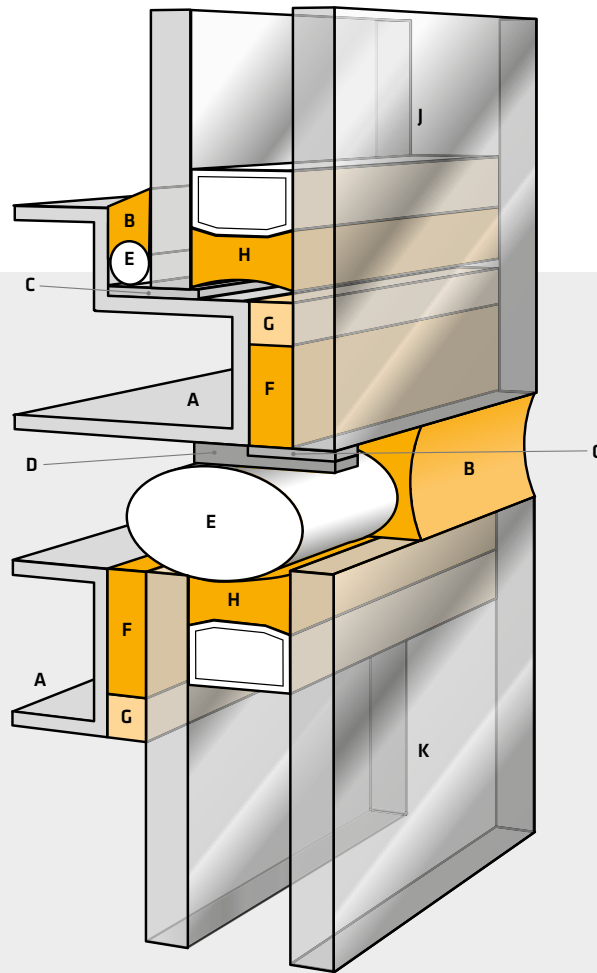

- A** Adapter frame
- B** Weatherseal
- C** Setting block
- D** Mechanical support
- E** Backing material
- F** Structural glazing joint
- G** Spacer tape
- H** Secondary edge seal
- J** Stepped insulating glass unit
- K** Symmetric insulating glass unit

STRUCTURAL GLAZING – CONVINCING ENERGY PERFORMANCE IN ALL DETAILS

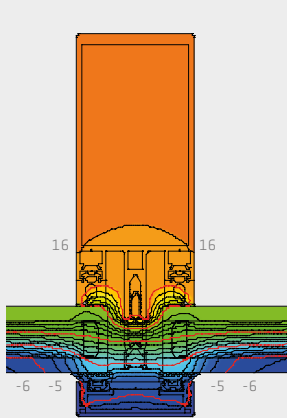
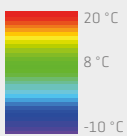

Fig. 1

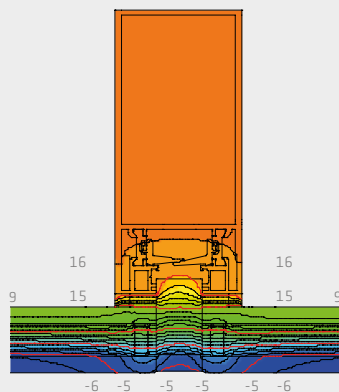

Fig. 2

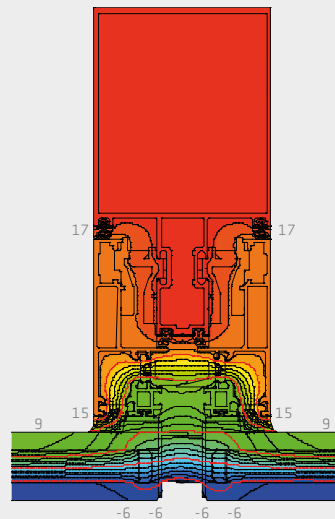

Fig. 3

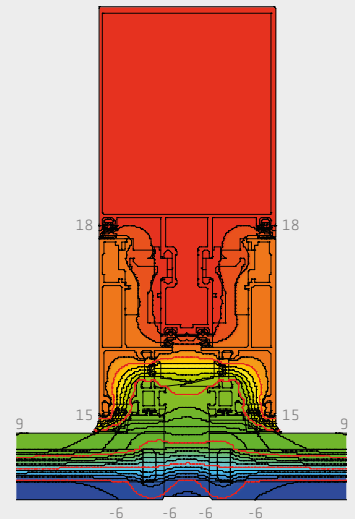

Fig. 4

Comparison of the Uf values show the better energy performance of the SG system (Fig 2: 1.2 Wm-2K-1) vs capped curtain wall system (Fig 1: 2.9 Wm-2K-1)

But some of the advantage is lost if the facade is not properly sealed. Compare Fig 3 (gaskets, 1.7 Wm-2K-1) and Fig 4 (wet sealant, 1.0 Wm-2K-1)

FACADE SYSTEM COMPONENTS – GLASS AND METAL FRAME

GLASS

1. Uncoated Float Glass

Float glass is generally suitable for all bonded glass facades. To reduce the risk of damage from glass breakage, use tempered or laminated glass (with polyvinyl butyral film, PVB or alternative foil materials, e.g. ionomers.) Sikasil® SG silicone adhesives ensure excellent adhesion to tempered glass without additional tests. Where laminated glass is used, we recommend carrying out compatibility tests.

2. Pyrolytic Coatings for reflective Glass (hard Coatings)

Coated glass optimizes the thermal performance of the facade while providing a particularly attractive optical effect. Pyrolytic coatings (hard coatings) of metal oxides are ideal for structural glazing, since they resist environmental conditions. Before application of Sikasil® SG and IG silicone adhesives adhesion test must be performed on the coatings.

3. Magnetron Coatings for lowE Glass (soft Coatings)

These coatings contain precious metals (such as silver) and are generally not resistant enough for use in structural glazing bonds. If necessary, strip off the coating around the bond. Adhesion must therefore be tested on the abraded specimens, since abrasion represents a modification of the surface, and is subject to various parameters. Always observe the glass manufacturer's instructions.

4. Ceramic Coatings

Ceramic coatings are used predominantly in the spandrel area. At the edge regions of the glass, they cover color differences within the insulating glazing edge seal and between the edge seal and the structural glazing adhesive. The adhesive strength of Sikasil® SG silicone adhesives has been proven in numerous projects and tests according to the European guideline for bonded glass structures (EOTA ETAG 002). However, since the composition of the coatings may vary greatly, individual adhesion tests must be carried out for each project.

ADAPTER FRAME

The adapter frame is usually made of the following materials:

- Anodized aluminum
- Powder-coated aluminum
- PVDF-coated aluminum
- Stainless steel

Sikasil® SG silicone adhesives and SikaHyflex® sealants adhere very well to these materials. Sika carries out additional tests to check the representative surface quality used in every individual project.

Furthermore the organic coating system has to be approved for structural glazing application by both coating producer and coater (e.g. complying EOTA ETAG 002 part 2). The durability of the coating system must be adequate to the life expectancy of the structural bonding application.

On organic coatings tried-and-tested pretreatment agents like Sika® Aktivator-205 and Sika® Primer-790 have proven to accelerate the formation of adhesion and optimize the adhesion profile and durability.

80 and 100 Victoria Street, London, 2005

Architects EPR Architects; Facade Josef Gartner GmbH



Sikasil® SILICONE SEALANTS IN DETAIL

SPECIALIZED PRODUCTS

High-modulus Sikasil® SG silicone adhesive sealants offer the best properties for this purpose. The latest development with highest design strength is described on page 22. Special high-modulus Sikasil® IG silicone secondary sealants allow very low argon loss rates in structural glazing facades. Sika's low-modulus SikaHyflex® weatherseals accommodate the movements between the structural glazing modules and durably seal them against wind and weather. The elastic seal can even reduce damage in small to medium-scale earthquakes and bomb blasts. Sikasil® FS silicones comply with international fire standards.

TAILORED PRODUCTS

Sealants are classified according to their curing mechanism into acidic (which emit acetic acid on curing) and neutral systems (which emit oxime or alcohol on curing). For facades, solvent-free, non-corrosive neutral technology is used almost exclusively. The exceptions are all-glass structures, which can also be sealed with acetic-curing sealants.

TYPICAL PROPERTIES OF NEUTRAL SEALANTS

- A wide range of adhesion properties for a variety of applications
- Outstanding adhesion and bonding power to glass and metal surfaces
- Early load-bearing, thanks to high initial elasticity
- Reliable and non-corrosive to sensitive materials when used in movement joints, expansion, construction and connection joints
- Application-specific curing time with different vulcanization rates and optimum curing
- Uniform long-term elasticity
- Good elastic recovery
- Durable and extremely strong
- Outstanding weathering and ageing resistance
- Extremely good UV and oxidation stability
- Good chemical resistance
- Resistant and flexible even with extreme temperature fluctuations from -50 °C to +150 °C
- Low shrinkage in vulcanization
- Long-term resistance to continuous rainfall

SEALANT COMPOSITION

Sikasil® silicone sealants generally consist of the following components:

- Silicone polymer
- Silicone plasticizer
- Silicone cross-linker
- Silicone adhesion promoter
- Reinforcing fillers (e.g. fumed silica)
- Possibly non-reinforcing fillers, such as silicates, chalks, etc.
- Optionally, additives such as emulsifiers, pigments and fungicides

ADAC Headquarters, Munich, 2011

Architects Sauerbruch Hutton Architects; Facade Josef Gartner GmbH

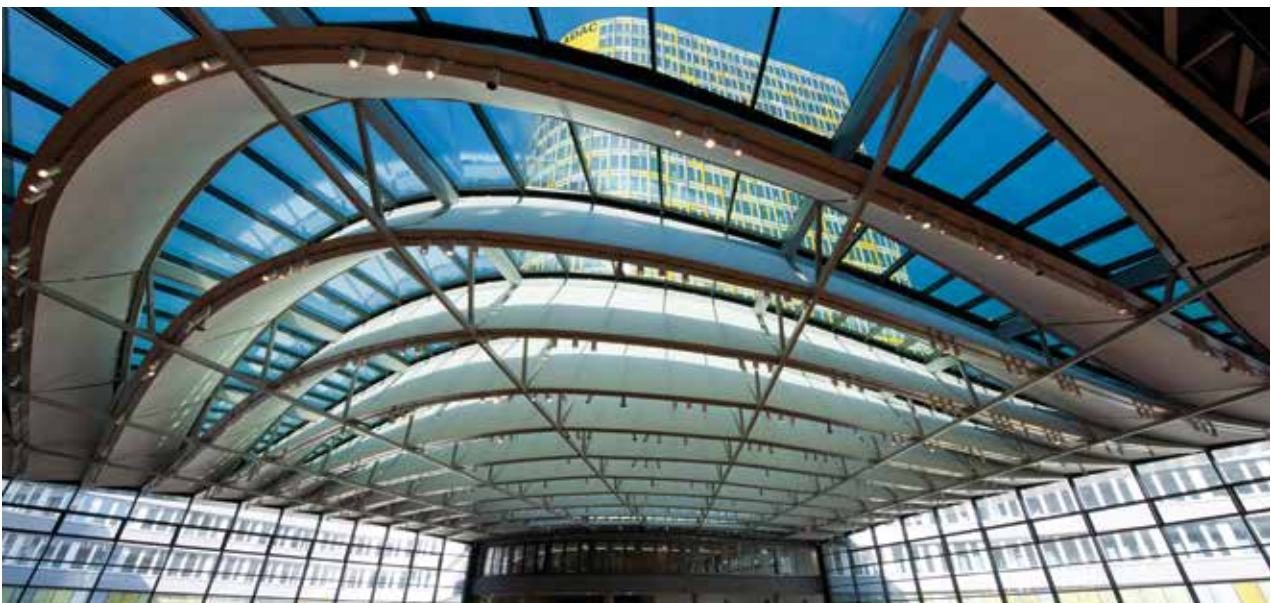

ONE-PART VS. TWO-PART SILICONES

Silicone sealants and adhesives are available both as one-part and two-part products. The number of components does not have an influence on the mechanical properties but has some consequences on the product application. Whereas one-part products are easy to use and mainly applied on site as weather proofing sealants from foil packs or cartridges the two-part products are preferably factory applied with machines from drums and pails and mainly used as high-modulus adhesives. For available packaging please check the relevant product datasheets or ask your Sika contact. The table on the right has summarized the most important product features and differences.



top:
Application machine for 2-part sealants out of drums and pails (factory application)
bottom:
Gun application of 1-part sealants out of foil packs and cartridges (on-site application)



PROPERTIES AND APPLICATION CHARACTERISTICS OF ONE- AND TWO-PART Sikasil® SILICONE SEALANTS

One-Part Systems

Ready-to-use grade. Already contains cross-linker and catalyst

Supplied in cartridges or foil packs, can be used immediately

Easy to use (field glazing in two-sided structural glazing, repair glazing, weatherseals)

Require atmospheric moisture for curing at room temperature

Curing starts at the surface and continues inwards relatively slowly

Curing rate depends on relative air humidity, temperature and joint depth (see Fig. 1)

Minimum time span between bonding and assembly of the structural glazing elements: 2 to 4 weeks depending on air humidity and joint dimensions

Joint bite limited to maximum 15 mm, otherwise curing takes too long and there is a risk of cracking

Two-Part Systems

Base compound and hardener are mixed during application

Supplied in drums and pails, components must be mixed by machine

Execution under controlled conditions in the factory resulting in higher quality of the bond

No atmospheric moisture required for curing

Once the components are mixed, curing begins uniformly throughout the joint with a gradual increase in viscosity

Curing rate depends virtually only on the temperature

Minimum time span between bonding and assembly of the structural glazing elements: 3 to 5 days, depending on frame materials

Should be used for thicker silicone adhesive sealant layers. Greater joint bite than 15 mm possible, since considerably higher curing rate and lower volume shrinkage on curing.

Efficient factory prefabrication of structural glazing elements possible. Elements are faster to transport and install

CURING RATE OF Sikasil® SILICONE SEALANTS

Curing characteristic of one-part silicones

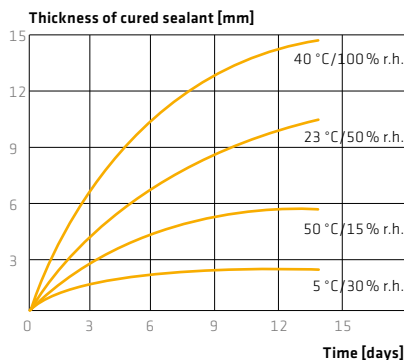

Fig. 1: Curing rate of one-part silicones such as Sikasil® SG-20 or Sikasil® WS-605 S

Curing characteristic of two-part silicones

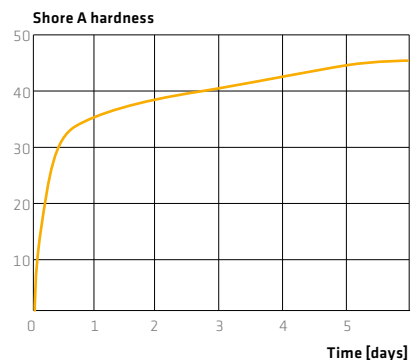

Fig. 2: Shore A hardness in the curing of two-part silicones, such as Sikasil® SG-500 or Sikasil® IG-25, as a function of time

MECHANICAL PROPERTIES

MECHANICAL PROPERTIES

Sealants are classified (e.g. according to ISO 11600 or ASTM C920) by their mechanical properties.

Tensile Stress or Modulus

This is the quotient of the tensile force measured at a particular elongation and the initial cross-section of the test specimen. For classification as a low-modulus sealant according to ISO 11600 (e.g. ISO 11600 25 LM), this must have a modulus of less than 0.4 N/mm² at 20 °C according to ISO 8339.

Important: In comparisons of data, the shapes of the test specimens are important. Measurements with dumbbell specimens according to ISO 37 and ASTM D 412 give much higher values than those on H-test specimens according to ISO 8339 or ASTM C1135, which are more similar to actual joint geometries and are therefore usually used for structural glazing tests.

Tensile Strength

This is the quotient of the maximum measured force and the initial cross section of the test specimen.

Elongation at Break

This is the quotient of the change in length measured at the instant of tearing and the initial measured length of the test specimen.

Shore A Hardness

This is the penetration hardness of polymers. It depends on the modulus of elasticity and the viscoelastic properties of the material. Higher Shore A values ensure a harder material. High-modulus structural glazing silicone sealants usually have Shore A values of over 30. The values for weatherseals are usually between 15 and 25.

MOVEMENT CAPABILITY

The movement capability is the total elongation and compression that a joint sealant undergoes during service. In the case of silicone sealants according to ISO 11600, it is between 20 and 25 % of the initial width. According to ISO 9047, classification 25 is based on elongation and compression cycles with an amplitude of $\pm 25\%$. In ASTM C920 movement capabilities of $\pm 50\%$ or even $+100/-50\%$ are classified.

ADHESION

Silicone sealants adhere very well to many substrates. The adhesion depends on the type of material to be bonded, the stresses, the type of adhesive bond and surface pretreatment. The surfaces must be absolutely clean and grease-free. Before the start of sealant application on any construction projection, always carry out adhesion tests on the surfaces in question.

H-SPECIMEN VS. DUMBELL

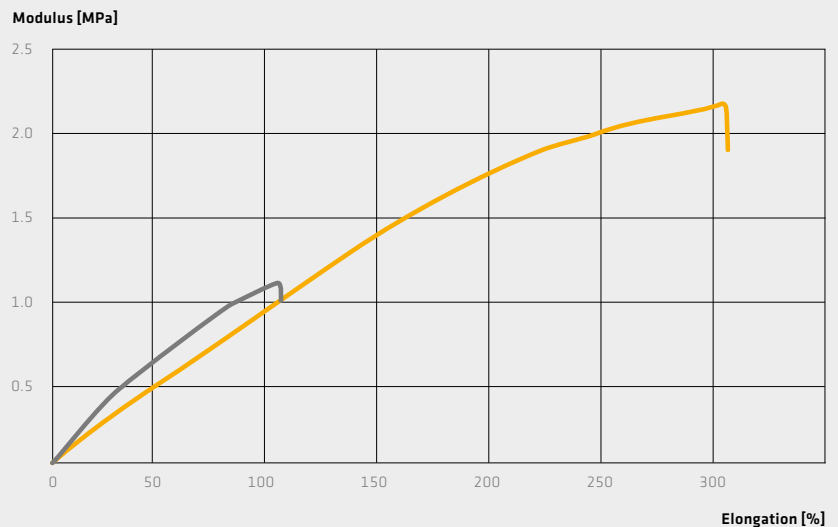
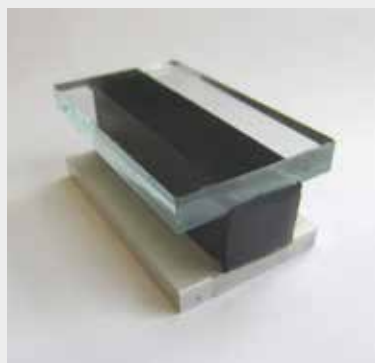

Fig. 3: Stress-strain curve, comparison of H-specimens and dumbbell

The grey stress-strain curve of H-specimen of Sikasil® SG-500 (compl. ASTM C1135 / ISO 8339) shows the behavior of the adhesive in the joint function.

The orange stress-strain curve of dumbbell of Sikasil® SG-500 (compl. ASTM D412 / ISO 37) shows the mechanical properties of the adhesive for FE modeling. For comparing datasheet values check the test methods first. Dumbbells always show much higher values than H-specimens.



BEHAVIOR AND RESISTANCE

WEATHERING AND AGEING RESISTANCE

Silicone sealants have better weathering and ageing resistance than other joint sealants. Their physical properties do not change, even after years of outdoor weathering.

COMPATIBILITY WITH COATING MATERIALS

Silicone sealants usually adhere well on coating materials (powder coatings, liquid paints and varnishes) on the construction materials, but this should always be tested. However, standard silicone sealants cannot be painted with liquid coating material (paints or varnishes). Streaking and running usually occurs during application.

Important: Most of the coating materials used in building construction and in almost all window constructions are less elastic than sealants. A continuous coating may therefore tear if the dimensional change of the sealant is greater than the elasticity of the coating. Elastic sealants in settlement joints must therefore never be completely coated. Only sealants subject to low movements up to approx. 5% can be coated completely. Sealants coming into contact with coatings must be compatible with them (in conformity with DIN 52452).

CHEMICAL RESISTANCE

Vulcanized silicone sealants have good resistance to weak acids and alkalis, polar solvents and salt solutions. Silicone sealant swells to a greater or lesser extent in solvents such as ketones, esters, ethers, aliphatic, aromatic and chlorinated hydrocarbons. It is restored to its original shape after evaporation of the solvents.

HIGH AND LOW TEMPERATURE BEHAVIOR

The stress/strain value (modulus) of silicone sealants – unlike organic sealants – remains nearly constant over a wide temperature range from -30 to +80 °C. The tensile strength increases at low temperatures. Silicone sealants are thus ideal for compensating for joint expansions occurring as construction elements cool to low temperatures. The tensile stresses in the joint flanks are not increased, and there is reduced risk of loss of adhesion and consequent adhesive fracture. Below -50 °C, there is partial crystallization of the silicone elastomers and the sealant hardens. At -123 °C (the glass transition temperature) embrittlement occurs. Silicone sealants are extremely heat resistant. In dry air up to +150 °C, all grades retain virtually their full elasticity. Special silicone sealant grades are even heat resistant up to +250 °C. It is important that silicone elastomer should be fully vulcanized before it is subjected to high temperatures, and that the curing byproduct has evaporated completely. Heat resistance can be further enhanced by subsequent annealing at slowly increasing temperature and with good ventilation.

SHELF LIFE

If stored in the original sealed containers at temperatures below 25 °C, silicone sealants have a shelf life of at least 12 months, and some grades at least 18 months.

GAS AND WATER VAPOR PERMEABILITY

At room temperature, the gas permeability of silicone sealants is about ten times higher than that of natural rubber. At 100 °C to 150 °C, the permeability values are approximately the same. The water vapor permeability according to DIN 53122, climate D, film thickness 2 mm, is approx. 20 gm⁻²d⁻¹.

SOME BASIC RULES – RESTRICTIONS ON USE

In structural glazing high loads are to be transferred to the sub-construction by high-modulus structural glazing adhesives. Thus low-modulus silicone sealants must not be used for structural glazing bonding.

Acetoxy-curing silicone sealants are incompatible with alkaline substrates such as mortar and concrete, and with corrosion sensitive metals such as lead, zinc, copper, brass and ferrous metals. Neutral silicones, e.g. Sikasil® WS-605 S or SikaHyflex®-305, shall be used instead.

Standard silicone sealants must not be used for sealing settlement joints and expansion joints between porous natural stone (e.g. granite, marble, sandstone, etc.). There is a risk of staining. We recommend SikaHyflex®-355 instead. See page 32.

Standard silicone sealants can cause environmental stress cracking in contact with pre-stressed acrylic and polycarbonate construction elements. Further product information is provided in the data sheets.

Fungicide-containing sealants, e.g. sanitary sealants, must not be used for the production of aquaria.

Silicone sealants do not adhere to polyethylene and polytetrafluoroethylene. Please ask us for suitable pretreatment methods, e.g. corona treatment.

Contact with organic elastomers (such as EPDM and Neoprene) can not only cause discoloration of the sealant but can also reduce its mechanical strength and cause adhesive failure. Please ask us for compatible recommendations.

30 St Mary Axe, (Swiss Re), London, 2004

Architects Foster & Partners; Facade Schmidlin AG ECL Contracts Ltd.



COEFFICIENT OF EXPANSION

The coefficient of cubic expansion of silicone sealants depends on the nature and the amount of fillers used. It is in the range $4 \times 10^{-4} \text{ K}^{-1}$ and $8 \times 10^{-4} \text{ K}^{-1}$.

The coefficient of linear expansion is approximately a third of the cubic expansion, i. e. from $1 \times 10^{-4} \text{ K}^{-1}$ to $3 \times 10^{-4} \text{ K}^{-1}$.

THERMAL CONDUCTIVITY

The thermal conductivity of silicone sealants depends on the nature and the amount of fillers used. It is in the range from 0.15 to $0.3 \text{ W K}^{-1} \text{ m}^{-1}$ at room temperature (DIN 52612).

PHYSIOLOGICAL CHARACTERISTICS

All silicone sealants emit by-products on curing. They may be acetic acid, alcohols or oximes, depending on the sealant grade. We therefore advise users to read the data sheet and safety data sheet in advance. In general, they should

be applied in a well-ventilated room. Vulcanized silicone sealants are non-toxic. Special grades are available for contact with foods and drinking water.

MICROBIAL RESISTANCE

Unlike organic sealants, silicone sealants are not attacked or degraded by microbes (bacteria or fungi). However, microbes can accumulate on the surface of dirty silicone sealants, particularly in warm and moist conditions occurring in bathrooms and kitchens. This causes discolored patches on the sealant surface without its mechanical properties changing. For warm and moist applications, therefore, a fungicide-containing sealant should be used.

TERMINOLOGY

Adhesion Tendency of a solid surface to stick to a second phase, which may be a liquid or a solid film.

Adhesion Loss Undesirable separation of the adhesion bond, e. g. separation of a joint.

Adhesion Value Force between an adhesive bond, or the force necessary to separate the bond.

Cohesion The integrity of substances as a result of chemical bonding or physical intermolecular forces.

Cohesive Fracture Undesirable material fracture, e. g. in the joint.

SOME RELEVANT INTERNET LINKS

www.aia.org
www.archdaily.com
www.archinform.de
www.architecture.com
www.architectureweek.com
www.ctbuh.org
www.emporis.com
www.eota.be
www.glassfiles.com
www.riba.com
www.skyscrapercenter.com
www.uia-architectes.org

SPECIAL SOLUTIONS

Sika has developed special products to cover most challenges in construction industry. Please note the incompatibilities mentioned on the left page. Further information is provided in the data sheets and application guidelines. We will be pleased to advise you on any type of application problem and find a solution.

Sikasil® SG SILICONE ADHESIVES

STRUCTURAL BONDING

Sika has developed one-part and two-part silicone adhesive sealants for structural glazing and insulating glazing applications, and each features specific advantages. Which of these systems is best for a particular application depends first and foremost on the specific requirements. Both systems offer maximum quality and maximum safety in every respect.

In addition they are characterized by the following special properties:

- High tensile strength
- High elastic recovery
- Low volume shrinkage on curing

The latest Application Guidelines can be downloaded from www.sika.com/ffi-downloads

DID YOU KNOW?

With 0.20 N/mm² Sikasil® SG-550 achieves the highest ETA approved SG design stress in tension in the market. For more details see page 22.

	Sikasil® SG-18	Sikasil® SG-20	Sikasil® SG-500	Sikasil® SG-500 CN	Sikasil® SG-550
Components	one-part	one-part	two-part	two-part	two-part ¹⁾
Curing System	neutral	neutral	neutrals	neutral	neutral
Processing	with guns from cartridges or foil packs	with guns from cartridges or foil packs	machine mixing	machine mixing	machine mixing
Installation of bonded elements	after 2 to 4 weeks ¹⁾	after 2 to 4 weeks ¹⁾	after 3 to 5 days ¹⁾	after 3 to 5 days ¹⁾	after 3 to 5 days ¹⁾
Maximum of joint bite ²⁾ [mm]	15	15	40	40	40
Skin forming time/pot life³⁾ [min]	~ 30	~ 15	~ 40 ⁶⁾	~ 60	~ 75
Permanently elastic range [°C]	-40 to +150	-40 to +150	-40 to +150	-40 to +150	-40 to +150
Shore A hardness ⁴⁾	~ 44	~ 39	~ 45	~ 40	~ 55
Tensile strength ⁵⁾ [N/mm²]	~ 1.1	~ 1.2	~ 1.0	~ 0.9	~ 1.6
Modulus at 100 % elongation ⁵⁾ [N/mm²]	~ 0.8 (50 %)	~ 0.9 (100 %)	~ 1.0 (100 %)	~ 0.9 (100 %)	~ 1.0 (25 %)
Elongation at break [%]	~ 75	~ 180	~ 100	~ 120	~ 80

1) Depends on joint dimensions and curing conditions, 2) limits by curing, bigger joints bites are possible if the access of air humidity and release of curing by-products is possible on both joints sides, e.g. with open-cell Sika® Spacer Tape HD. Contact Sika Technical Department for details. 3) @ 23 °C/50% rel. humidity, 4) ISO 868, 5) ISO 8339-A 6) bigger joints bites are possible if the release of by-products is possible on both joints sides, e.g. with open-cell spacer tapes.

These figures are intended as a guide and should not be used in preparing specifications. For technical information about the products, please ask for the latest respective data sheets.

Sikasil® SG-500

- Two-part SG system
- For machine application
- Neutral curing
- Fast vulcanization and through-cure
- Excellent UV and weathering resistance
- High mechanical strength
- ETA certified and CE-marked
- Complies with ASTM C1184, ETAG 002, EN 13022, EN 1279-2, -4, ETA approved (ETA 03/0038), marked with CE and SNJF VEC

Sikasil® SG-500 CN

- Two-part SG system
- For machine application
- Neutral curing
- Fast vulcanization and through-cure
- Excellent UV and weathering resistance
- High mechanical strength
- Complies with ASTM C1184, ASTM C920 class 25, GB 16776-2005

Sikasil® SG-550

- Two-part SG system
- For machine application
- Neutral curing
- Fast vulcanization and through-cure
- Excellent UV and weathering resistance
- Extremely high mechanical strength
- Good processing properties on hydraulic pump systems*
- High design strength for smallest SG joints
- Complies with ASTM C1184, ASTM C920, class 12.5, ETAG 002 and EN15434, ETA approved (ETA 11/0392) marked with CE and SNJF VEC

* e.g. Reinhard Technik, Ecostar 250, Lisec TAL 50 and TAL 60, TSI Mastermix XL and XS, Dopag Visco-Mix H200; pneumatic pumps have to be tested

Sikasil® SG-18

- One-part SG system
- Neutral curing
- UV-resistant and weather-resistant
- High mechanical strength
- Ready to process
- High modulus
- Complies with ASTM C1184, ASTM C920 class 12.5, ETAG 002, EN 1279-2

Sikasil® SG-20

- One-part SG system
- Neutral curing
- Odorless
- UV-resistant and weather-resistant
- Very high mechanical strength combined with high elasticity
- Ready to process
- Complies with ASTM C1184, ASTM C920 class 25, ETAG 002, EN 13022, GB 16776-2005, ETA approved (ETA 06/0090), marked with CE and SNJF VEC

COMPATIBLE SPACERS

Sika® Spacer Tape HD has mechanical properties perfectly adjusted to meet the curtain wall requirements. They provide the essential UV resistance and durability, and are the perfect installation aids for structural glazing elements. The open cell structure of the Sika® Spacer Tape HD is permeable to air humidity and thus increases the speed of vulcanization of one-part Sikasil® SG adhesive sealants. Two-part adhesives reach full mechanical strength only if curing by-products can be released freely. With joints bites bigger than 40 mm only open-cell Sika® Spacer TapeHD shall be used. These PU foam tapes have been thoroughly tested for compatibility with all Sikasil® silicone sealants, and a guarantee to this effect is provided.

Sika® Spacer Tape HD is available in the standard thicknesses of 4.8, 6.4, 8.0 and 9.5 mm.

STANDARDS AND GUIDELINES

A wide variety of local standards and guidelines have become established worldwide. The most important are:

In Europe

EOTA ETAG No. 002-1998 (2012): a guideline on the application and testing of SG adhesives, which is adhered to in most EU states and takes local regulations into account.
CSTB 3488: describes the French SG regulations for adhesives.

In the USA

ASTM C1184: comprehensive SG adhesive specification standard.
ASTM C1401: guideline for SG applications.
ASTM C1392: guide for SG failure evaluation
ASTM C1487: guide for SG remedying

In China

GB 16776-2005: SG certification standard
JGJ 102: SG design standard

In countries without own structural glazing standard, ASTM C1184 / ASTM C1401 or EOTA ETAG 002 are usually applicable.

Sika offers a complete set of Sikasil® SG, IG and SikaHyflex® products including Sika® Spacer Tape HD and the IG butyl in a harmonized shade of grey. Your Sika sales manager will be pleased to give you further details. See page 30.

JOINT DESIGN

CORRECT PLANNING IS ESSENTIAL

In structural glazing, the adhesive joints should be planned and arranged according to optical requirements, but they should also take into account dimensional changes in the adjacent parts under the effect of temperature and the movement capability of the silicone adhesive. The joint design thus combines shape with functionality.

PLEASE NOTE

SEVEN CRITERIA MUST BE OBSERVED:

1. The joint seal must be able to freely accommodate tensile and compressive movements between the joint edges. Three-sided adhesion of the sealant must be avoided, because it inevitably results in damage to the joint (see Fig. D on page 20).
2. The joint bite h must not exceed 15 mm for Sikasil® SG-18 and Sikasil® SG-20. For bigger joints up to 40 mm, use Sikasil® SG-500 or Sikasil® SG-500 CN. With Sikasil® SG-550 joint dimensions can be minimised. Consult Sika Technical Department for details.
3. The ratio of joint bite h to joint thickness e should be at least 1:1 and at most 3:1.
4. The minimum joint bite is always 6 mm, irrespective of the calculated value.
5. The joint thickness e should be at least 6 mm.
6. Always round the result up, never down.
7. The structural joints must not be subjected to external loads as a result of forces such as settlements, shrinkage, creep or permanent.



Heron Tower, London, 2011

Architects Kohn Pedersen Fox Associates
Facade Scheldebouw (UK)

CALCULATING JOINT BITE h

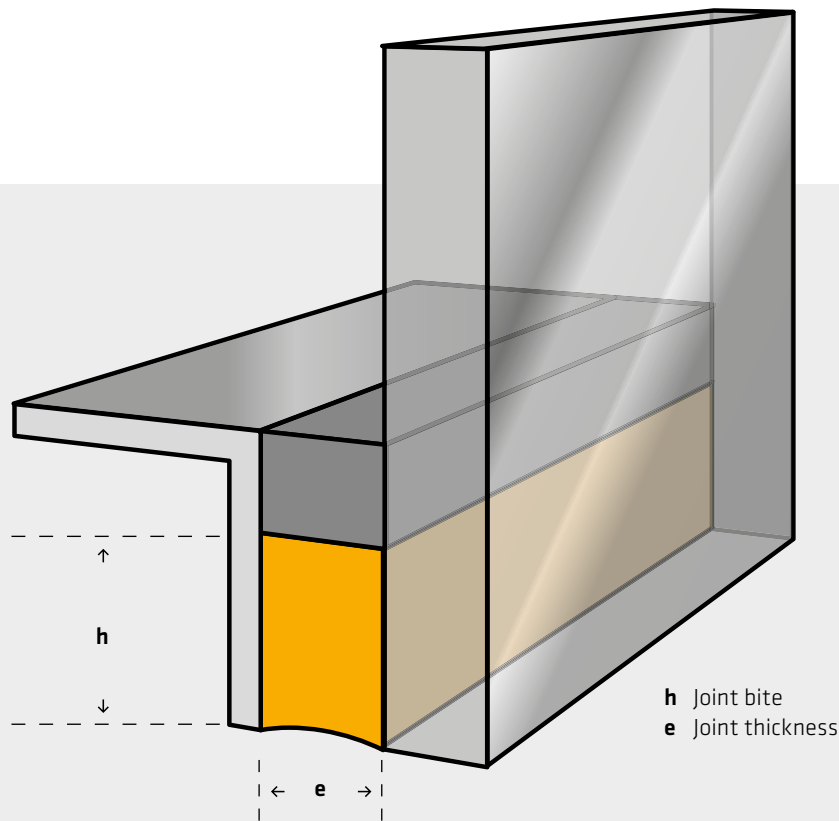

h Joint bite
e Joint thickness

Joint bite h as a function of the wind load in supported constructions:

$$h = \frac{a \times w}{2 \times \sigma_{dyn}}$$

h minimum bite of the adhesive joint [mm]
a length of the short edge of the glass pane or of the element [mm]; with irregularly dimensioned glass elements: longest of the short glass edges¹⁾
w maximum wind load to be received [kN/m²] (100 kp/m² = 1 kPa = 1 kN/m²)
σ_{dyn} maximum adhesive stress for supported constructions [kPa].
For **σ_{dyn}** values of Sikasil® products see page 20.

Example 1 (with Sikasil® SG-500):

Maximum wind load = 4.0 kN/m²
Pane dimensions: 2.5 m x 1.5 m
Result: 21.43 mm
The joint bite is thus at least 22 mm.

¹⁾ If the sides of the glass panes are of varying length, then the length of the longest side is used for the calculation.

Joint bite h as a function of the dead load in non-supported constructions:

$$h = \frac{G \times 9.81}{l_v \times \tau_{stat}}$$

h minimum bite of the adhesive joint [mm]
G weight of the glass or of the element [kg]
l_v length of the vertical adhesive bond [m] complying with ETAG 002. In ASTM C1401 I is the whole perimeter of the pane
τ_{stat} permissible stress of the adhesive for non-supported constructions [kPa]
For **τ_{stat}** values of Sikasil® products see page 20.

Example 2 (with Sikasil® SG-500):

Glass dimensions:
Height: 2.5 m
Width: 1.5 m
Thickness: 10 mm

Density of glass: 2.5 kg/dm³

Result ETAG: 17.52 mm
The joint bite is thus at least 18 mm.
Result ASTM: 10.95
The joint bite is thus at least 11 mm.

Joint bite h as an interaction of combined tension and shear load: Mohr tension cycle

$$h_{tot} = \frac{h_{tensile}}{2} + \sqrt{\left(\frac{h_{tensile}}{2}\right)^2 + h_{shear}^2}$$

h_{tot} minimum bite of the adhesive joint [mm]
h_{tensile} bite of the adhesive joint from tensile load, e.g. wind load [mm]
h_{shear} bite of the adhesive joint from shear load, e.g. dead load [mm]

This ultimate strength interaction for combined tension and shear is also recommended in ASTM C1401-07. Alternately, for a combined loading condition, the shear stress can be considered with the tensile stress.

Example 3 for non-supported construction (with Sikasil® SG-500):

h_{tensile}: 22 mm
h_{shear}: 18 mm
Result: 31.43 mm
The joint bite is thus at least 32 mm.

With all structural glazing constructions, the adhesive bond is subject to considerable shear movements. The joint thickness (glue line thickness) must therefore be designed so that the movement capability of the adhesive is not exceeded.

Criteria for Calculating the Joint Thickness e

- Dimensions of the elements' maximum temperature differences to be expected
- Coefficients of thermal expansion of the materials to be bonded
- Estimated value for joint thickness: half of joint bite, at least 6 mm

PLEASE NOTE

CONSIDER ALL CAUSES OF STRESS IN THE JOINT.

1. All causes of movement must be taken into account:

- Thermal effects due to different coefficients of thermal expansion between the glass and the support structure. If the joint dimensions are to be the same for a complete construction project, they must be calculated according to the dimensions of the largest pane.
- Other causes, such as shrinkage, subsidence or locally confined stresses.

2. Observe all tolerances.

These include the tolerances for cutting glass, and/or metal, and installation tolerances.

3. The application temperature must be between +5 °C and +40 °C.

4. Avoid three-sided adhesion of the sealant so as not to restrict joint movement. Detail D is absolutely forbidden!

CALCULATING THE JOINT THICKNESS E

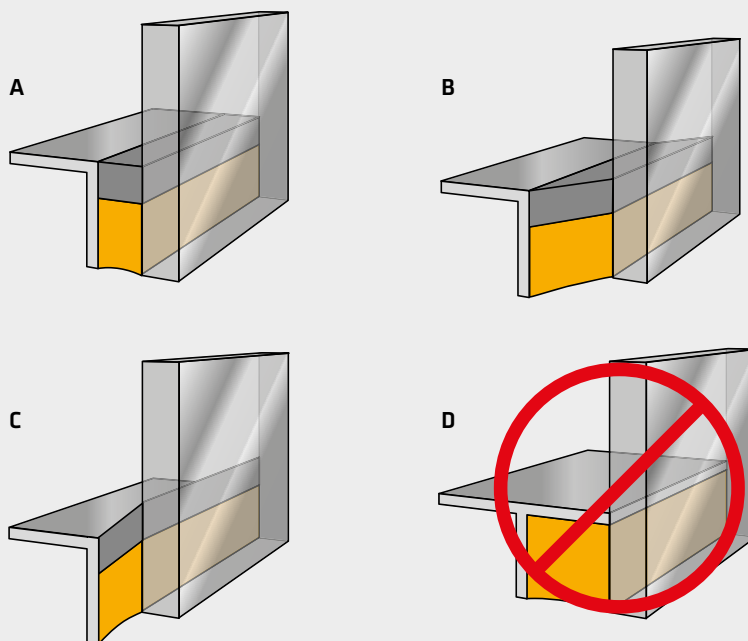

- A** Right joint dimension in its original state (h = joint bite, e = joint thickness).
B, C Besides tensile movements the adhesive bond also absorbs shear movements in all directions.
D Bonding on three sides must be avoided. Detail D is forbidden!

Sikasil®	ETAG			ASTM		Movement capability (ASTM C719)
	σ_{dyn}	τ_{dyn}	τ_{stat}	σ_{dyn}	τ_{stat}	
SG-500	0.14 MPa	0.105 MPa	0.0105 MPa	0.138 MPa 20 psi	0.007 MPa 1 psi	± 12.5%
SG-500 CN	-	-	-	0.138 MPa 20 psi	0.007 MPa 1 psi	± 25%
SG-550	0.20 MPa	0.13 MPa	0.013 MPa	0.207 MPa 30 psi	0.007 MPa 1 psi	± 12.5%
SG-20	0.17 MPa	0.12 MPa	0.012 MPa	0.138 MPa 20 psi	0.007 MPa 1 psi	± 25%
SG-18	-	-	-	0.138 MPa 20 psi	0.007 MPa 1 psi	± 12.5%
IG-25	0.14 MPa	0.101 MPa	0.010 MPa	0.138 MPa 20 psi	0.007 MPa 1 psi	± 12.5%
IG-25 HM Plus	0.19 MPa	0.13 MPa	0.011 MPa	0.138 MPa 20 psi	0.007 MPa 1 psi	± 12.5%

1. Deformation of the SG Structure

$$\Delta l_{v,h} = l_{v,h} \times [(\alpha_f \times \Delta T_f) - (\alpha_g \times \Delta T_g)]$$

Calculation of the deformation of the long and short panel edges to take account of the different expansion and contraction of glass and adapter frame (thermally induced movements in the shear direction).

$\Delta l_{v,h}$	change in length [mm]
l_v	vertical reference length [mm] in dead load supported systems: l_v = total height of glass unit in non-supported systems: l_v = half the height of glass unit
l_h	horizontal reference length l_h = half the width of glass unit [mm]
T_f	average temperature difference of frame (approx. 30 – 60 K)
T_g	average temperature difference of glass (approx. 30 – 60 K)
α_f	expansion coefficient of the frame material (aluminum: $23.8 \times 10^{-6} \text{ K}^{-1}$, stainless steel: $12 \times 10^{-6} \text{ K}^{-1}$)
α_g	expansion coefficient of glass $9 \times 10^{-6} \text{ K}^{-1}$

3a. Calculation of the minimum joint Thickness e (ASTM C1401)

$$e \geq \frac{\Delta l}{\sqrt{2c + c^2}}$$

Sikasil® SG silicone adhesive sealants are permitted maximum elongation of $\pm 12.5\%$ ($c = 0.125$) or $\pm 25\%$ ($c = 0.25$). The total of expansion and contraction must not exceed 25% (50% for SG-500 CN). With these restrictions, the minimum joint depth e can be calculated.

2. Total Movements

$$\Delta l = \sqrt{\Delta l_v^2 + \Delta l_h^2}$$

The calculated deformations of the long and short panel edges yield the total movements according to the formula above (Pythagoras' theorem).

Δl	total change in length
v	vertical
h	horizontal

3b. Calculation of the minimum Joint Thickness e (ETAG 002)

$$e \geq \frac{(G \times \Delta l)}{\tau_{des}}$$

G	= Modulus of elasticity in shear tangential to the origin: ($G = E/3$)
E	= Modulus of elasticity in tension or compression tangential to the origin
τ_{des}	= permissible stress in shear of the adhesive for supported constructions [MPa] For τ_{des} (= τ_{dyn}) values of Sikasil® products see page 20.

According to ETAG 002 a joint ratio of $e \leq h \leq 3e$ is advisable. For a joint ratio $> 3:1$, the bending effects in the elastic joint must be considered.

Example 4 (with Sikasil® SG-500):

Glass dimensions: 2.5 m x 1.5 m
(see example 1)
Temperature difference frame: 30 K
Temperature difference glass: 60 K
Maximum elongation: 12.5% ($c = 0.125$)

G (SG-500): 0.50 MPa
 τ_{des} (SG-500): 0.105 MPa
Result Step 1: $\Delta l_v = 0.44$ mm;
 $\Delta l_h = 0.13$ mm
Result Step 2: $\Delta l = 0.45$ mm
Result Step 3a (ASTM): $e = 0.88$ mm
Result Step 3b (ETAG): $e = 2.14$ mm

Minimum joint width is 6 mm. But due to the recommended ratio of $h:e \leq 3:1$ the joint width shall be 8 mm for supported example 1 and 11 mm for non-supported example 2.

For support in joint calculations please contact your Sika FFI Competence Center. For standard situations calculate your joint dimensions with the Sika Joint calculator.
www.sika.com/ffi-joint-calculator

DID YOU KNOW?

All Sikasil® IG secondary sealants and SG adhesives carrying an ETA are ETAG 002 approved for type III and IV for systems without mechanical dead load support.

ULTIMATE SAVINGS BY STRENGTH

Sikasil® SG-550

Sikasil® IG-25 HM Plus

Since the beginning of structural glazing for most of the silicone adhesives the design strength has been fixed at 0.14 N/mm². This started to change in 2006 when the design strength of Sikasil® SG-20 was rated with 0.17 N/mm². Sika offers two innovative products with a mechanical strength outperforming all existing insulating glass and structural glazing silicone adhesives. In the latest ETA approvals issued in November 2011 the IG secondary edge seal Sikasil® IG-25 HM Plus has been evaluated with 0.19 N/mm². The structural glazing adhesive Sikasil® SG-550 is even rated with unmatched 0.20 N/mm². With almost 90 % elongation at break it can accommodate high movements in the SG modules. Figures 1 and 2 demonstrate impressively the improvements compared to standard silicone products on the market.



Torre Puig, Barcelona, 2013
Architects Rafael Moneo, Lucho Marcial; **Facade** Permasteelisa Spain.
 First European project with Sikasil® SG-550

	Standard design	New design	Saving/Reduction
Products	Sikasil® IG-25 Sikasil® SG-500	Sikasil® IG-25 HM Plus Sikasil® SG-550	
IG sealant dimension	17 x 12 mm	13 x 12 mm	25 % volume
SG joint dimension	30 x 9.5 mm	21 x 6.4 mm	60 % volume
Size of spacer tape	9 x 9.5 mm	6 x 6.4 mm	55 % volume
Width of mullion	95 mm	70 mm	26 % width

DID YOU KNOW?

In bomb blast tests Sikasil® SG-550 outperformed standard SG adhesives impressively, allowing bondline reductions up to 50 %. For detailed results contact the Technical Department of Sika Industry.

Sikasil® SG-550

Extremely high mechanical strength and design factors:

- Tensile strength: 1.6 N/mm²
- Design tensile strength σ_{dyn} : 0.20 N/mm²
- Design shear strength τ_{stat} : 0.013 N/mm²

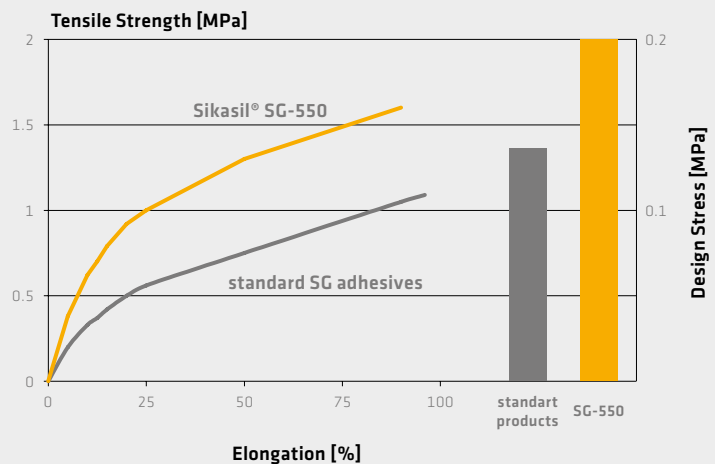
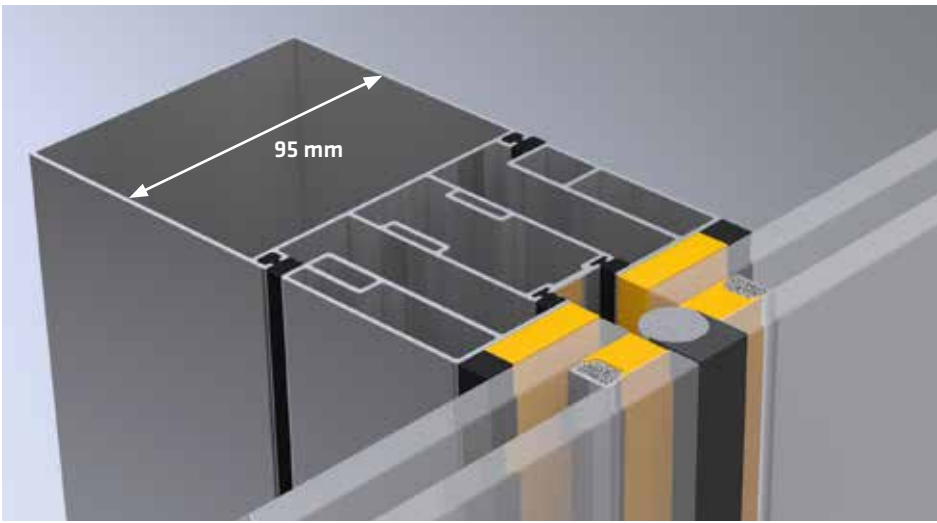

Fig. 1: Comparison of stress-strain curve and design strength of Sikasil® SG-550 with standard SG adhesives



COMPARISON: STANDARD PRODUCT

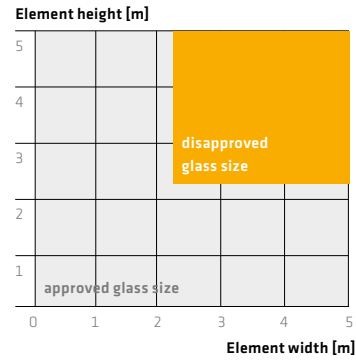
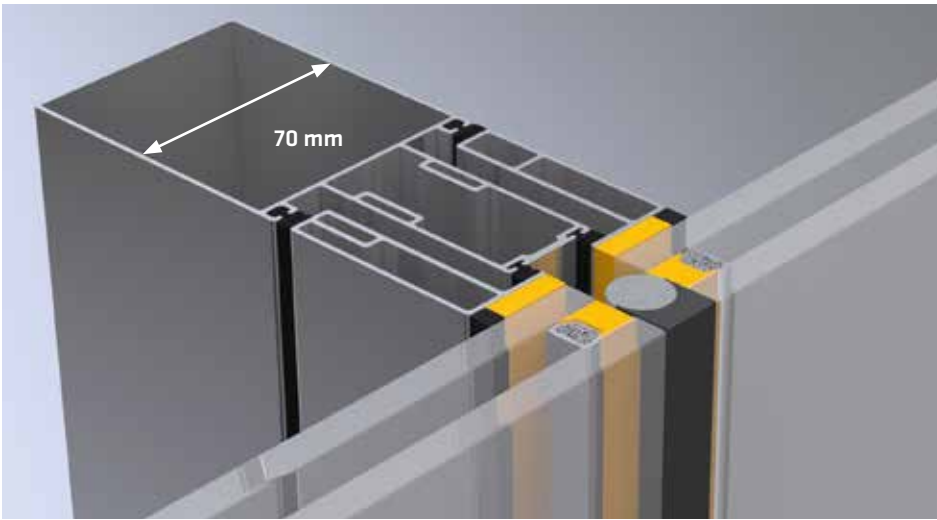

Fig. 3a: Feasible SG element size with Sikasil SG-500
SG Joint Dimension: 12 mm x 6mm; wind load: 1.50 kPa; dead load supported



HIGH-STRENGTH PRODUCT

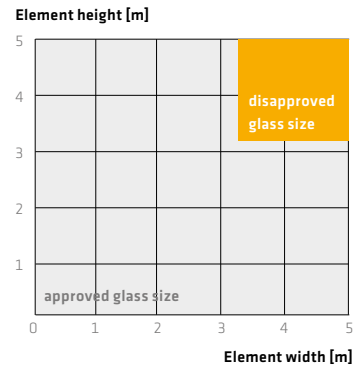

Fig. 3b: Under the same conditions as in Fig. 3a the facade elements can be much bigger with Sikasil® SG-550. Vice versa the joint bite for the same element sizes can be 30 % smaller, the total joint volume even 60 %

MATERIAL SAVINGS IN ALL DETAILS

The higher strength of the adhesives has an enormous saving impact on the material consumptions:

For a project with a wind load of 5 kPa and glass dimensions of 1.6 x 3.5 m we have calculated the savings:

- SG joint: 60 %
- IG joint: 23 %
- Spacer tape: 55 %
- Aluminum: ~8 %

More details and sizes are visualised in the drawings above.

Let the sun shine in

Modern architecture is light and transparent. It requests filigree frames in light weight aluminum constructions for large airport and sports hall facades or widespanning glass roofs. In the sample above the aluminum aspects have been reduced by 25 %. The slimmer the frames the more transparent is the facade, the higher is the solar heat gain.

Sustainability all-over!

Sikasil® IG-25 HM Plus

Extremely high mechanical strength and design factors:

- Tensile strength: 1.4 N/mm²
- Design tensile strength σ_{dyn} : 0.19 N/mm²
- Design shear strength τ_{stat} : 0.011 N/mm²

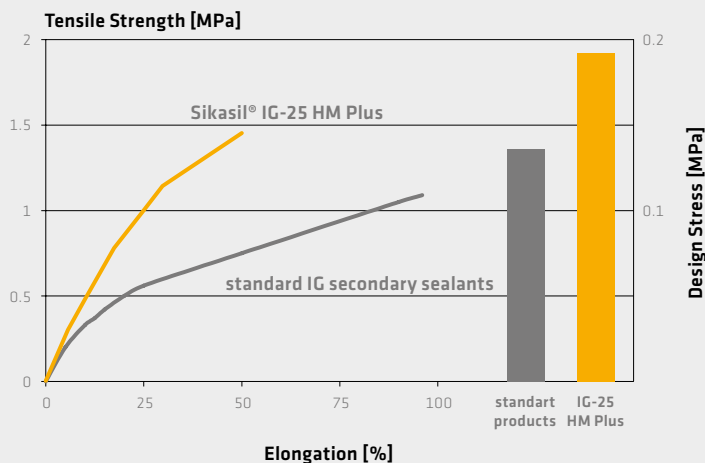

Fig. 2: Comparison of stress-strain curve and design strength of Sikasil® IG-25 HM Plus with standard IG products

INSULATING GLAZING

Keeps Energy Costs Low

THE FACADES are mainly responsible for the energy balance of a building. The excellent thermal insulating effect of bonded double or triple glazed units with coated glass can save much of the energy otherwise consumed for heating or cooling. The air trapped between the bonded panes is a poor heat conductor and therefore forms a good insulating layer between the outdoor and indoor air.

THERMAL INSULATION INCLUDED

The insulating glazing edge seals are predominantly made of bent aluminum or stainless steel spacers filled with a desiccant, thermoplastic polyisobutylene (PIB) as a primary seal and installation aid, and an elastic sealant as a secondary edge seal. Only high-modulus silicone is approved as a secondary seal in structural glazing facades. Sikasil® IG silicone sealants were specifically developed to meet requirements of insulating glazing and feature special advantages:

- **UV and weathering resistance**
- **Durability**
- **Material compatibility**

INTEGRATED SYSTEMS

In insulating glazing, double or triple glazing alike, it is particularly important that no water vapor should penetrate into the space between the panes, since it would condense as water on the cold pane. To avoid this during the whole service life of an IG unit, use a double-sealed edge seal system: see drawing on opposite page.

- Aluminum, stainless steel, or plastic spacers (A) ensure the necessary distance between panes (D).
- The desiccant (B) absorbs any moisture that penetrates through the edge seal.
- The polyisobutylene primary (D) (seal serves as an installation aid, sealing against moisture and minimizing gas leakage in the case of insulating glazing units filled with noble gas (e.g. Argon, Krypton).
- The secondary edge sealant (E) bonds the panes together, provides the double glazing with mechanical stability, and is also a moisture barrier.



Telefónica Headquarters, Madrid, 2006
Architects Rafael de la Hoz

DUAL SEAL INSULATING GLASS - THE PRINCIPLE

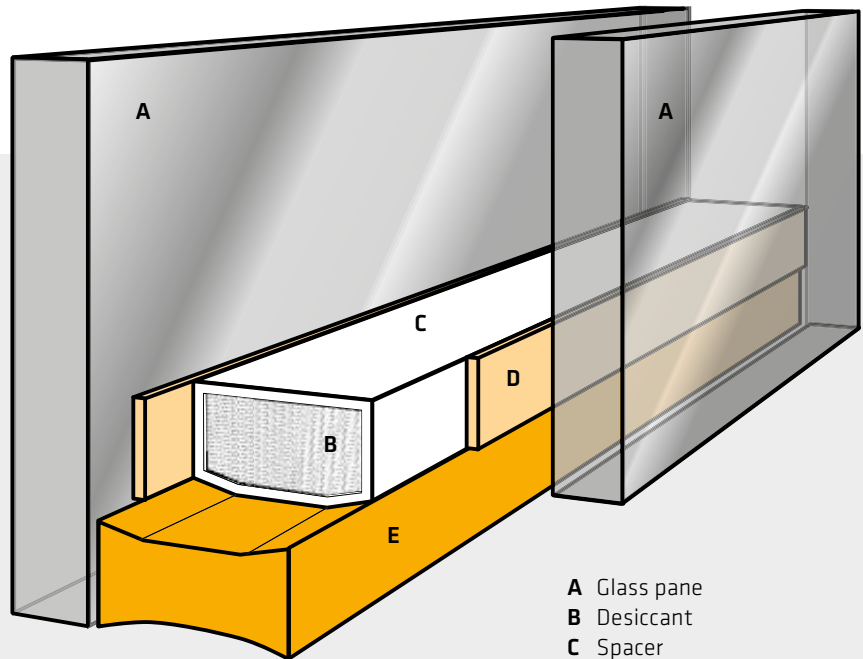

- A Glass pane
- B Desiccant
- C Spacer
- D Primary sealant
- E IG secondary edge seal



Hospital Rey Juan Carlos, Madrid, 2012
Architects Rafael De La-Hoz; Facade by Permasteelisa Spain; Curved Glass Cricursa

Sikasil® IG SECONDARY SEALANTS

TAILORED PROPERTIES

The sealant is chosen according to the individual requirements of the insulating glazing unit. Sika offers Sikasil® IG silicone sealants for the secondary edge seals of insulating glazing units. These sealants are characterized not only by outstanding tooling and bonding characteristics, but also by unparalleled UV stability. This permits durable constructions with a uniformly high quality of workmanship.

Sikasil® IG-25 HM Plus

- Two-part silicone secondary edge seal
- For machine application
- Outstanding processing properties (dosing and tooling)
- Extremely high mechanical strength
- Very high design factor for slim edge sealing
- Excellent weathering and UV resistance
- Extremely high resistance to water and moisture
- Structural capabilities
- Suitable for most kinds of curtain wall insulating glazing units
- Complies with ETAG 002, EN 13022, EN 15434, EN 1279-2, -3, 4, CEKAL and ETA approved (ETA 11/0391), marked with CE and SNJF VI-VEC

Sikasil® IG-16

- One-part secondary edge seal
- Neutral curing
- Ready to process
- Outstanding tooling properties
- Excellent weathering and UV resistance
- Suitable for stepped double glazing units in curtain walls
- Complies with EN 1279-2, -3, 4

Sikasil® IG-25

- Two-part secondary edge seal
- For machine application
- Outstanding processing properties (dosing and tooling)
- High mechanical strength
- Structural capabilities
- Excellent weathering and UV resistance
- High resistance to water and moisture

- Suitable for most kinds of curtain wall double glazing units
- Complies with ASTM C1184, ASTM C1369, GB 16776-2005, ETAG 002, EN 15434, EN 1279-2, -4, CEKAL and ETA approved (ETA 05/0068), marked with CE and SNJF VI-VEC

APPLICABLE STANDARDS

The test requirements laid down in international standards are designed to ensure an acceptable service life of the insulating glazing unit used in a facade. The climatic test usually includes cyclic conditioning of small double glazing units and subsequent testing of vapor permeability (dew point temperature).

The most important standards are: EN1279, Glass in building – insulating glass units

- Part 1, generalities, tolerances, system descriptions
- Part 2, moisture vapor penetration

- Part 3, inert gas leakage rates
- Part 4, physical attributes of edge seals
- Part 5, evaluation of conformity
- Part 6, factory production control

EN13022 and EN15434: Standards for insulating glazing in SG curtain walls.

The most important ASTM standards are:

- ASTM C1369-07: Standard Specification for Secondary Edge Sealants for Structurally Glazed Insulating Glass Units
- ASTM C1249-06a(2010): Standard Guide for Secondary Seal for Sealed Insulating Glass Units for Structural Sealant Glazing Applications
- ASTM E2188-10: Standard Test Method for Insulating Glass Unit Performance
- ASTM E2190-10: Standard Specification for Insulating Glass Unit Performance and Evaluation

Sikasil® IG SECONDARY EDGE SEALANTS

	Sikasil® IG-16	Sikasil® IG-25	Sikasil® IG-25 HM Plus
Curing system	neutral silicone	neutral silicone	neutral silicone
Components	one-part	two-part	two-part
Processing	with guns from cartridges or foil packs	machine mixing	machine mixing
Maximum of seal height [mm]	~ 15 ⁴⁾	~ 50	~ 50
Applications: - Standard IG for windows and capped CW systems - Symmetrical IG for SG - Stepped IG for SG - IG in two-sided SG - IG for bolted curtain walls - Gas-filled IGU	X X ⁵⁾ X X ⁵⁾ X	X X X X	X X X X X
Skin forming time/pot life¹⁾ [min]	~ 25	~ 45	~ 40
Permanently elastic range [°C]	- 40 to +150	- 40 to +150	- 40 to +150
Shore A hardness ²⁾	~ 45	~ 45	~ 65
Tensile strength ³⁾	~ 0.9	~ 0.9	~ 1.4
Modulus at 100 % elongation ³⁾ [N/mm²]	~ 0.8 (50 %)	~ 0.8 (50 %)	~ 0.8 (50 %)

1) @ 23 °C/50 % rel. humidity, 2) ISO 868, 3) ISO 8339-A, 4) limits by curing, 5) If the IG secondary seal has a structural function, Sikasil® IG-25 or IG-25 HM Plus has to be used.

These figures are intended as a guide and should not be used in preparing specifications. For technical information about the products, please ask for the latest respective data sheets.

Sikasil® IG-25 HM Plus

ENERGY-SAVING WITH INERT GAS FILLING

Beside glass coatings the gap-filling with inert gas is one means of reducing heat losses. With an argon-filled cavity the U-value of an IG unit can be reduced by 0.3 W/m²K. This means an oil saving potential of up to 3 litres per year per square meter of glass facade and even 4 times more energy equivalents for cooling in hot climates. For big glass facades this not only means a high potential of energy saving but also a tremendous reduction of carbon dioxide and hence the greenhouse effect.

The high argon diffusion rate of the silicones has been the obstacle to the use in argon-filled IG units. Bending movements of the glass panes due to changes of temperature and atmospheric pressure (page 29, Fig. 7) and the non-elastic behavior of PIB cause

leakage of the primary seal and thus cause high gas loss rates in IG units sealed with silicone. With the development of the high-modulus IG secondary edge seal Sikasil® IG-25 HM Plus the glass panes in IG units are very tightly held together. Movements in the butyl layers, caused by temperature and pressure changes, are minimised. As a consequence leakages in the butyl primary seal, the main barriers against argon penetration, are prevented. As the PIB layer in fact is the argon barrier, comprehensive application know-how and quality control during the IG production are crucial. For the stability requested in SG facades these IG units can be produced with rigid boxshaped spacer bars (aluminum or stainless steel).

ENERGY SAVING FOR MORE THAN 30 YEARS – SUSTAINABILITY ALL-OVER

With the argon loss rate of 0.5 % per year, in average achieved at the tests complying with European standard for argon-filled IG units EN1279-3, after 30 years an argon content of 80% can be expected in the IG cavity. Even after 30 years the energy transfer coefficient of IG unit (U_g value) should have increased only by less than 0.1 W/m²K. This could mean that for the whole service life of a glass facade the high energy performance of the argon-filled insulating glass units remains almost unchanged.



Fig. 4a: Feasible triple glazed IG unit with Sikasil® IG-25 and the same conditions as in Fig. 4b IG configuration 8/10/4/10/8 IG Joint dimensions 10 mm x 6 mm

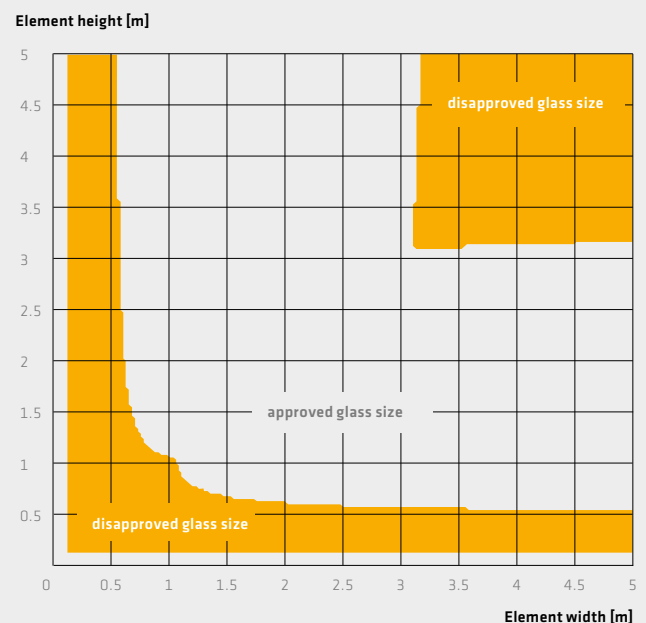

Fig. 4b: Under the same conditions as in Fig. 4a the IG units can be much bigger with Sikasil® IG-25 HM Plus. Vice versa the seal height for the same unit sizes can be 25 % smaller.

SEAL HEIGHT CALCULATION

CALCULATION OF JOINT DIMENSIONS IN STEPPED CONFIGURATIONS

The IG seal height r for the inside pane is calculated solely by taking the environmental loads into account when the smaller inside pane is supported by setting blocks. It is advisable to have the seal height checked by one of our FFI Competence Center. r should be at least 6 mm.

NON-STEPPED (SYMMETRICAL) DOUBLE GLAZING UNITS

In the case of double glazing units in mechanically supported structural glazing constructions, the outer glass pane is held onto the frame by means of the secondary edge seal. The minimum seal height r is calculated for two cases A and B (see formulas on the right).

SUPPORT FROM OUR SIKA FFI COMPETENCE CENTERS

For precise and reliable calculations of seal height please contact your Sika FFI Competence Center. For standard situations calculate your joint dimensions with the Sika Joint calculator. www.sika.com/ffi-joint-calculator

IMPORTANT

SG adhesive bonding of an unsupported IG unit is not recommended because of excessively high stress in the IG secondary edge. If inevitable you should contact the Facade Competence Center FCC Switzerland.

SEAL HEIGHT CALCULATION IN IG UNITS

- A** SG joint bite h
- B** Symmetrical double glazing unit
- C** IG seal height r
- D** Stepped double glazing unit

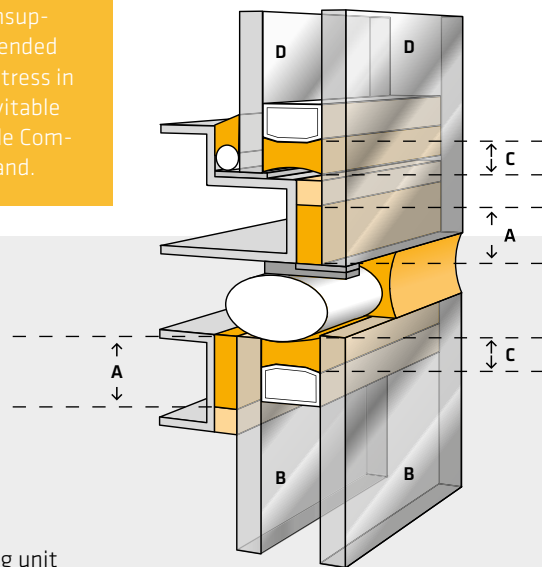

Simple calculation of the seal height in symmetric configurations according to EOTA ETAG 002-2004

A) When the thickness of the outer glass pane > thickness of the inner glass pane:

$$r = \frac{a \times w}{2 \times \sigma_{dyn}}$$

B) When the thickness of the outer glass pane < thickness of the inner glass pane:

$$r = \frac{a \times w}{4 \times \sigma_{dyn}}$$

r height of the insulating glass secondary seal [mm]
 a longest of the short glass edges of the project [mm]
 w maximum wind load to be expected [kN/m²]
 σ_{dyn} permissible adhesive stress for supported constructions.
 For design values of Sikasil® IG products see page 20.

STEPPED DOUBLE GLAZING UNIT

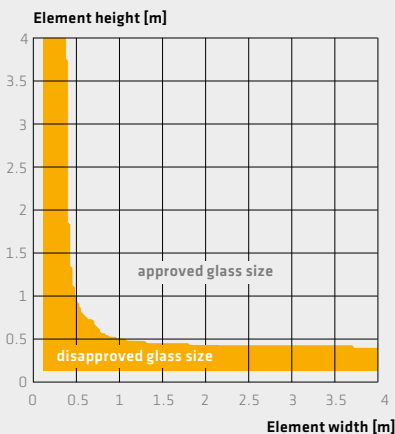

Fig. 1 Only climatic loads are relevant for sealant height calculation

SYMMETRICAL DOUBLE GLAZING UNIT

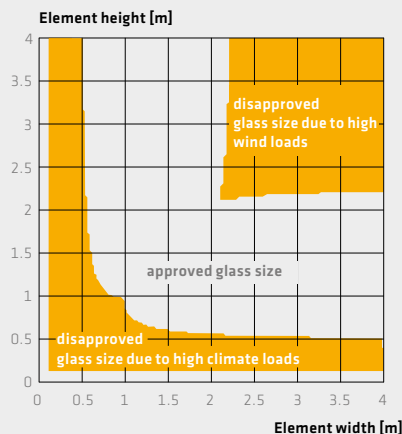

Fig. 2 Climatic and wind load are relevant for sealant height calculation

EFFECT OF ENVIRONMENTAL LOADS

Especially for small glass panes and non-standard formats, for a precise calculation of the IG sealant height there are 4 steps to consider:

1. Calculation of isochoric Pressure p_0

The isochoric pressure is a theoretical pressure caused by climatic loads such as max. estimated difference of temperature ΔT and atmospheric pressure Δp_{atm} and the difference in altitude ΔH of production site of the IG unit and its installation site.

An average value for p_0 of 16 kPa has to be considered. For extreme changes of temperature or altitude, p_0 has to be calculated with the formula below.

2. Estimation of Glass Deflection

Based on the value of p_0 the deflection of the glass panes is calculated by various methods (e.g. Plate method or Timoschenko method). The deflection is influenced by the pane thickness and their size (see Fig. 4 and 5). Small, thick panes require big seal heights (see Fig.

6, e.g. IGU 0.75 x 0.75 m: minimum seal height of 18 mm).

3. Real internal Pressure

The increase of the cavity volume by the glass deflection reduces the isochoric pressure to the real internal pressure. The pump action caused by environmental loads is shown in the illustrations in Fig 7.

4. Total Load on the secondary Seal

The sum of the climatic load of point 3 and the wind load results in the final load on the IG edge seal (see Fig. 1 and 2).

$$p_0 = (\Delta T \times 0.34 \text{ kPa/K}) + \Delta p_{atm} + (\Delta H \times 0.012 \text{ kPa/m})$$

INFLUENCE OF GLASS THICKNESS ON SEAL HEIGHT

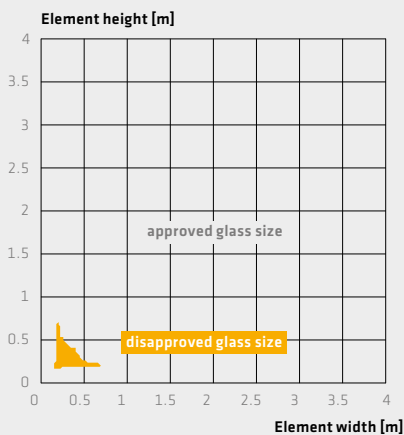

Fig. 3 Residential fenestration
Glass: 4/12/4 mm, p_0 : 12 kPa
Seal height: 6 mm

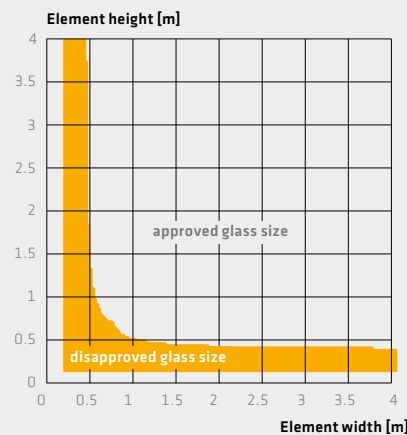

Fig. 4 Commercial glazing in highrise buildings
Glass: 6/12/6 mm, p_0 : 20 kPa
Seal height: 6 mm

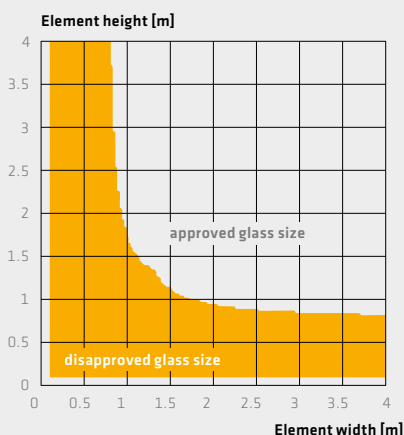

Fig. 5 Protective glazing
Glass: 10/12/8 + 8 mm, p_0 : 20 kPa
Seal height: 6 mm

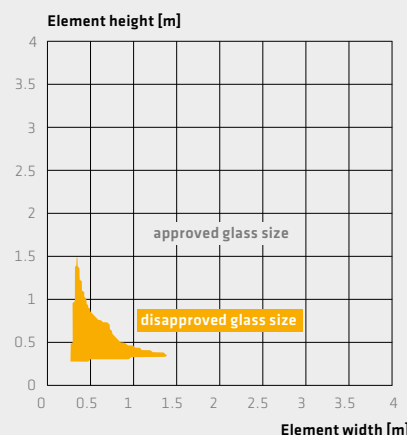
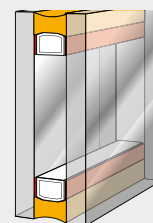
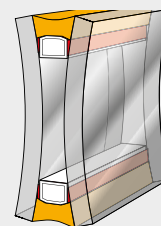

Fig. 6 Protective glazing, increase of seal height
Glass: 10/12/8 + 8 mm, p_0 : 20 kPa
Seal height: 18 mm with IG-25
Alternatively 13 mm with IG-25 HM Plus

Fig. 7 Glass deflection due to climatic loads



Standard external influences



High atmospheric pressure, low temperature

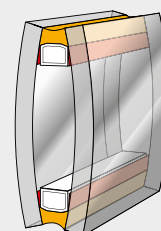

Low atmospheric pressure, high temperature

SikaHyflex® WEATHERSEALS

Effective Protection Against the Elements

QUALITY AND OPTICAL appearance of a curtain wall are critically dependent on appropriate weather sealing. The individual elements are ultimately subject to extreme movements due to temperature changes, moisture (in the case of concrete), shrinkage of construction materials (wood, concrete), sound, wind and vibrations, which may affect the joints and adjacent elements.

PERFECT APPEARANCE

The joints between the elements may be effectively sealed with preformed gaskets or alternatively with UV and weather resistant silicone sealants. SikaHyflex® silicone sealants preserve the quality and perfect optical appearance of the facade in the long term, thanks to their outstanding advantages:

- UV and weathering resistance
- Improved impermeability to air and driving rain
- Very good movement absorption

DIMENSIONING OF WEATHERPROOFING JOINTS

In general

- The joint edges must run parallel to a depth of twice the joint width, but at least 30 mm. This gives the backing material sufficient grip.
- For most sealants, the joint width must be at least 4 times the expected joint movement, which results from 25 % movement capability
- The optimal ratio of joint width to depth is 2:1 (see page 31 drawing top right)

PROJECT-SPECIFIC ADHESION TESTS

For weather-tight sealing of a curtain wall, it is essential to ensure optimum adhesion of the sealant to the surfaces. Before the sealant is used, it should therefore be individually tested for perfect adhesion to specimens of the project material at Sika's FFI Competence Center.

WEATHERSEALANTS FOR GLASS AND METAL FACADES

SikaHyflex®-305

- Ready-to-use one-part sealant
- Neutral curing
- UV and weathering resistant
- Highly flexible
- Complies with ASTM C920 class 50, TT-S-001543 A, TT-S-00230 C, EN 15651-1, -2 (F EXT-INT CC 25LM, G CC 25 LM), CE marked

Sikasil® WS-605 S

- Ready-to-use one-part sealant
- Neutral curing
- Non-streaking on glass and metal surfaces, reduces facade cleaning cost
- UV and weathering resistant
- Highly flexible
- Complies with ASTM C920 class 50, TT-S-001543 A, TT-S-00230, ASTM C1248 C, ISO 11600 F-G 25 LM, DIN 18540, DIN 18545, EN 15651-1, -2 (F EXT-INT CC 25LM, G CC 25LM), marked with CE, SNJF, AENOR, ATG

INDIVIDUAL COLOR SCHEME

For weatherseals and natural stone sealants, Sika offers project-specific color matching services. In addition to the wide range of standard colors, see color samples on the right page, Sika also offers individual special colors on request. Please note that special colors are subject to special delivery conditions such as minimum order quantities and delivery times. Your Sika sales manager will be pleased to give you further details.



PERFECT COLOR MATCHING IN GREY S6 FROM LEFT TO RIGHT

- Polyisobutylene (PIB)
- Sikasil® SG, IG, SikaHyflex®
- Sika® Spacer Tape HD

WATER/VAPOR PROOFING MEMBRANES

Connections of the glass facade to the concrete structure can be too wide for wet sealing. For sound water proofing Sika offers sophisticated vapor control membrane systems (see page 36).

WEATHERPROOFING GASKETS

UV-resistant silicone rubber gaskets are suitable for use as structural glazing weatherseals. All gaskets (particularly non-silicones such as EPDM) have to be individually tested for compatibility according to ASTM C1087 or EOTA ETAG No. 002.

STANDARDS AND GUIDELINES

Because of the requirements for the sealant, standards for weatherseals are significantly different from those for structural glazing applications.

ISO 11600 is the world's first standard to combine the classification of widely different sealant grades and their tests. However, national standards, such as ASTM C920 and DIN 18545 are also important, not only because of local practices, but also because of specific characteristics such as the abrasion test (DIN 18545) or early movement capability (DIN 18540).

In Europe sealant must be tested against EN 15651, parts 1-4 and CE marked.
 part 1 – Sealants for facade elements
 part 2 – Sealants for glazing
 part 3 – Sealants for sanitary joints
 part 4 – Sealants for pedestrian walkways

SikaHyflex® TYPICAL APPLICATION

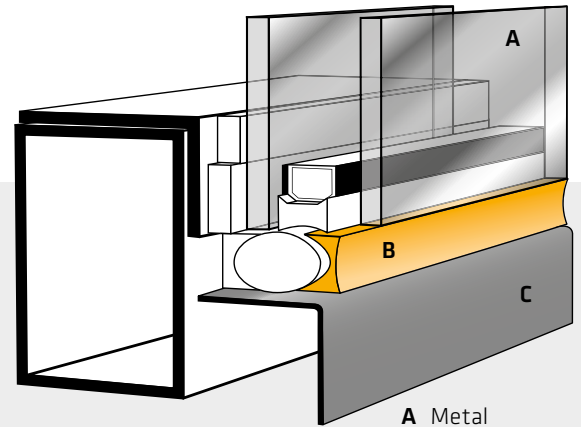

- A Metal
- B Weatherseal
- C Double glazing

COLOR GUIDE



For color cards with silicone swatches ask your Sika sales representative.

	SikaHyflex® -305	Sikasil® WS-605 S	Sikasil® WS-680 SC ⁴⁾
Components	one-part	one-part	one-part
Use	Weather seal	non-streaking WS on glass and metal	WS for self-cleaning glass
Curing system	neutral	neutral	Silicone modified polymer (MS)
Skin forming time ¹⁾ [min]	~ 15	~ 25	~ 12
Permanently elastic range [°C]	-40 to +150	-40 to +150	-40 to +90
Shore A hardness ²⁾	~ 25	~ 30	~20
Tensile strength ³⁾ [N/mm²]	~ 0.5	~ 0.5	
Modulus at 100 % elongation ³⁾ [N/mm²]	~ 0.3	~ 0.3	

1) @ 23 °C/50 % rel. humidity, 2) ISO 868, 3) ISO 8339-A, 4) WS-680 SC available in black only
 These figures are intended as a guide and should not be used in preparing specifications.
 For technical information about the products, please ask for the latest respective data sheets.



Republic Polytechnic Center, Singapore, 2006

Architects Fumihiko Maki, DP Architects

Sealed with Sikasil® WS-605 S, after >5 years no signs of streaking effect

NATURAL STONE SEALING

SEALANTS SUITABLE FOR NATURAL STONES

Natural stones such as granite, marble and sandstone are highly sensitive materials when used on facades. Where an inappropriate sealant is used, there may be staining of the joint edges or streaking, which greatly impairs the optical appearance of the facade. Sika therefore recommends special system-compatible SikaHyflex® silicone sealants ideally suited for use with extremely sensitive natural stone elements, or connecting metal facades and curtain walls to natural stone elements.

They contain no staining compounds that could migrate into the pores of the natural stone. We therefore describe them as non-staining. These non-staining silicone sealants are also recommended for glass facades in order to reduce streaking on glass panes and metal panels and to minimize the need to clean the facade.

SYSTEM-COMPATIBLE PRIMERS

Use Sika® Primer-210 or Sika® Primer-3 N to ensure long-term adhesion to stones of all types. Exact instructions for applying primer and sealant are given in our application guidelines.

APPLICABLE STANDARDS

The worldwide most frequently quoted standard for non-staining sealants is ASTM C1248: Standard Test Method for Staining of Porous Substrates

SikaHyflex®-355

- Weatherseal for natural stone facades
- Ready-to-use one-part sealant
- Neutral curing
- No staining on natural stone
- UV and weathering resistant
- Highly flexible
- Complies with ASTM C920, TT-S-001543 A, TT-S-00230, ASTM C1248 C, EN 15651-1, -2 (F EXT-INT CC 25HM, G CC 25HM), CE marked

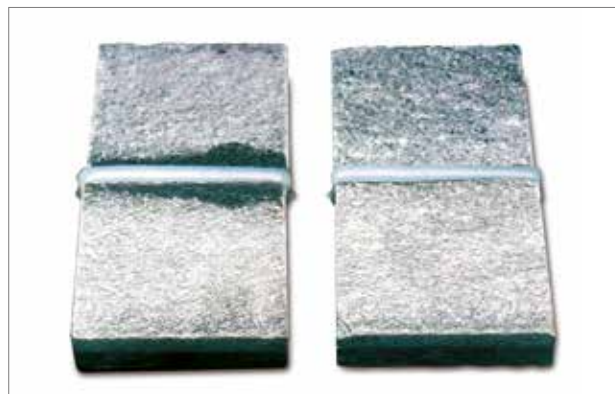

Using the wrong sealants causes staining of natural stone elements (see left specimen).

The right specimen has been sealed with SikaHyflex®-355 and exposed for 4 weeks to 70 °C under 50% compression.



Pangu Plaza, Beijing, 2008
Architects C.Y. Lee & Partners Architects & Planners
Facade Shanghai Huayi

SikaHyflex® TYPICAL NATURAL STONE JOINT

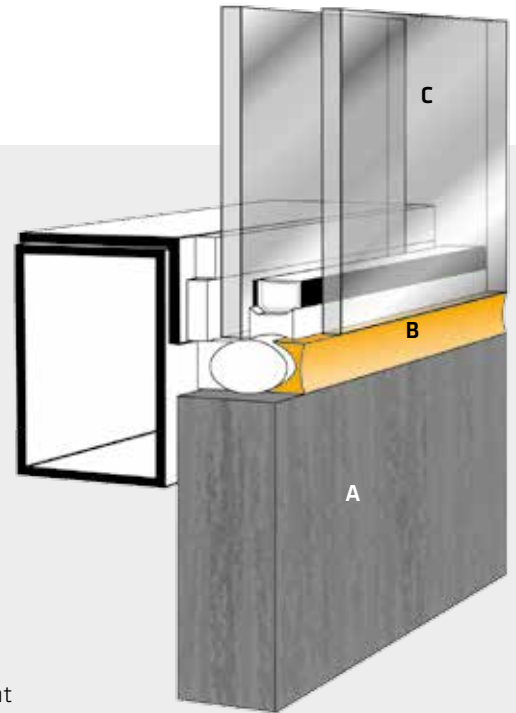

- A** Natural stone
- B** Non-staining sealant
- C** Double glazing

	SikaHyflex®-355
Components	one-part
Curing system	neutral
Skin forming time ¹⁾ [min]	~ 20
Permanently elastic range [°C]	-40 to +150
Shore A hardness ²⁾	~ 22
Tensile strength ³⁾ [N/mm²]	~ 0.5
Modulus at 100 % elongation ³⁾ [N/mm²]	~ 0.3

1) 23 °C/50 % rel. humidity, 2) ISO 868, 3) ISO 8339-A.
 These figures are intended as a guide and should not be used in preparing specifications.
 For technical information about the products, please ask for the latest respective data sheets.

IMPORTANT

Since all natural stones are very sensitive materials, a non-staining test shall be carried out at our FFI Competence Centers before any natural stone sealing operation. This is an essential precondition for non-staining guarantee.

FIRE-RATED SEALING

FIRE-RATED SEALING

Many casualties have been reported in serious fire catastrophes, not only because of fire but of smoke poisoning. The integrity of the joints is inevitable and gives fire brigades a chance to rescue people. Sika offers 4 hours fire-rated sealants both for vertical joints in facades and for horizontal floor joints between the facade and the floor slabs.

The fire-retardant silicone product range is supplemented with following fire-rated products:

Acrylic sealant Sikacryl® -620 Fire
 PU foams SikaBoom®-F, SikaBoom®-FR
 Backing materials Sika Backer Rod Fire, Sika RV.

Sikasil®-670 Fire

- Weatherseal for fireproof facades
- Ready-to-use one-part sealant
- Neutral curing
- Non-sagging
- UV and weathering resistant
- Highly flexible
- Complies with EN 15651-1 (F EXT-INT CC 25LM), CE marked

Sikasil® FS-665 SL

- Fire-rated, self-leveling sealant for horizontal joints
- Ready-to-use one-part sealant
- Neutral curing
- Self-leveling
- UV and weathering resistant
- Highly flexible
- Tested against BS476, part 20: 4 hours fire-rated

- Classified DIN 4102, B1
- Complies with EN 15651-4 (PW INT 25LM), CE marked

STANDARDS AND GUIDELINES

A wide variety of local standards and guidelines have become established worldwide. The most important are:

In Europe

- EN 13501, parts 1-5, Fire classification of construction products and building elements
- BS 476, part 20: Fire resistance tests

In the USA

- UL 94: Flammability Tests of Materials
- UL 1479: Fire Tests of Through-Penetration Firestops
- UL 2079: Tests for Fire Resistance of Building Joint Systems

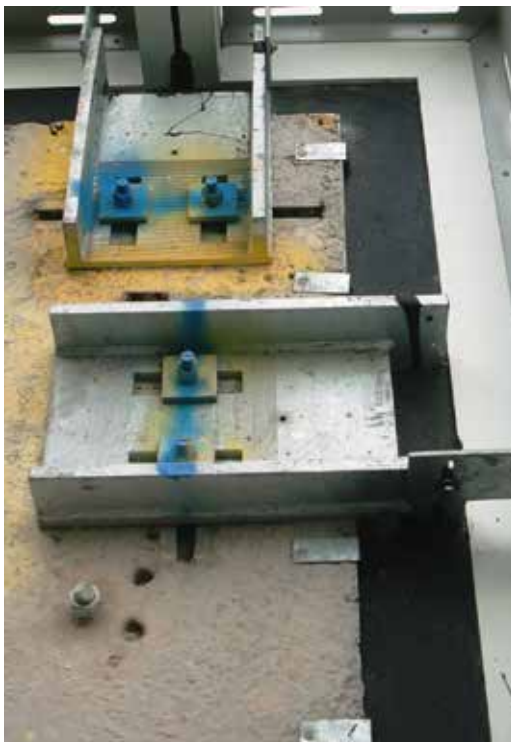

Application of Sikasil® FS-665 SL

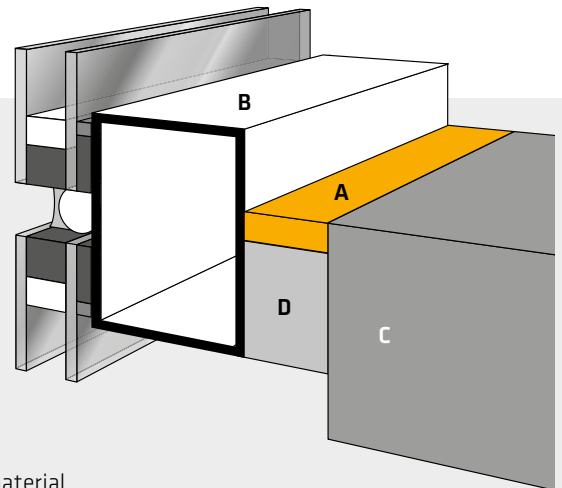

Sikasil® FS FLOOR JOINT APPLICATION

- A Sikasil® FS-665 SL
- B Facade profile
- C Floor slab
- D Fire retardant insulation material

	Sikasil®-670 Fire	Sikasil® FS-665 SL
Components	one-part	one-part, self-leveling
Curing system	neutral	neutral
Skin forming time ¹⁾ [min]	~ 24	~ 50
Permanently elastic range ²⁾ [°C]	-40 to +150	-40 to +150
Shore A hardness ²⁾	~ 16	~ 15
Tensile strength ³⁾ [N/mm ²]	~ 0.5	~ 0.8
Modulus at 100 % elongation ³⁾ [N/mm ²]	~ 0.3	~ 0.3

1) @ 23 °C/50 % rel. humidity, 2) ISO 868, 3) ISO 8339-A.

These figures are intended as a guide and should not be used in preparing specifications.

For technical information about the products, please ask for the latest respective data sheets.

ANCILLARY PRODUCTS

For Complete Structural Glazing and Weather Sealing

SYSTEM-ORIENTED EXECUTION

Perfect structural glazing execution requires careful coordination of details. Sika therefore offers a wide range of ancillary products for preparing substrates and processing sealants. These auxiliaries integrate into the whole facade product system and are carefully matched to Sikasil® silicone sealants. They will round off your structural glazing job.

For system-compatible Sika® Spacer Tape HD see page 17.

PRETREATMENT FOR OPTIMUM ADHESION

Thorough cleaning of the glass and metal surfaces is essential for reliable bonding of the Sikasil®SG and SikaHyflex® silicones. Therefore Sika supplies special products with optimized adhesion to a wide variety of materials. Our FFI Competence Centers will carry out thorough tests on the project materials to determine the best primer to use on the metal frame employed. Based on our experience and the test results, we will make specific product

recommendations for each structural glazing project. Clear float glass does not usually need to be primed where Sikasil® silicone products are used.

	Application
Sika® Cleaner P	Cleaner for all types of plastics and powder-coated metals
Sika® Cleaner G&M	Cleaner for highly contaminated glass and anodised aluminium
Sika® Aktivator-100	Cleaner/activator for anodized aluminum and enamelled glass
Sika® Aktivator-205	Cleaner/activator for many organic coatings (PVDF, PPC) and stainless steel
Sika® Primer-210	Primer for porous, vitreous surfaces
Sika® Primer-790	Primer for organic coatings (PVDF, PPC)
Sika® Mixer Cleaner	Cleaner for two-part mixing machine



SikaMembran® SYSTEM

Perfect Vapor Proofing in All Climates



5 Aldermanbury Square, London, 2005
Architects Eric Parry Architects; **Facade** Lindner-Schmidlin UK



University College London, 2005
Architects Llewelyn Davies Yeang Architects; **Facade** Fahrni AG

MEMBRANE APPLICATION EXAMPLES

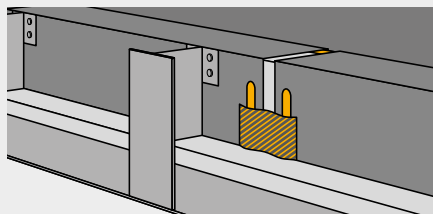

In ventilated facades SikaMembran® provides an adequate vapor control barrier throughout the whole year's climatic conditions. Water vapor must not be trapped in the structure.

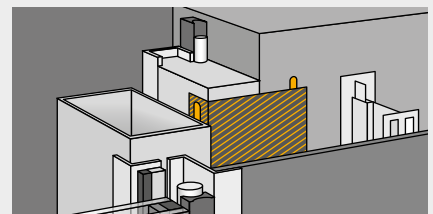

For wide gaps between the curtain wall and concrete structure SikaMembran® is the best solution.

WATER VAPOR IN BUILDINGS

Along with wind-driven rain, water vapor alone can also become a major problem in the structural framework. If the air is cooled to below the dew point, the excess moisture condenses as liquid water within the structure.

A “moisture transport mechanism” of this kind where water migrates through structural members in the form of vapor is particularly apparent in climates like that of Western and Central Europe and other similar climatic regions in the winter months. There is more water vapor in the atmosphere in heated rooms than there is in the outside air, and their difference in concentration is balanced by vapor diffusion from the inside to the outside. This phenomenon is obviously reversed in tropical regions with a hot, damp climate outside but with cool, air-conditioned rooms inside.

According to German Standard DIN 4108 (succeeded by EN 13984) “Thermal Insulation in Buildings”, a structural element must be designed so that an unacceptable quantity of condensed water is not produced inside the structure; for instance when water vapor diffuses moving from inside to outside and meets a material with a very high vapor diffusion resistance and/or a layer of thermal insulation.

As a rule of thumb the equivalent air layer thickness (s_d value) of the colder side shall smaller than the s_d value of the warmer side. The vapor diffusion resistance of SikaMembran® Universal

has been optimized in a way that under most climatic conditions it can be used on both sides.

Membranes can be combined with wet seal on one side see details on page 36. For calculation of s_d value of the joints or membranes use following formula:

$$S_d = \mu \times d$$

- μ diffusion resistance coefficient
- μ (polyurethane): 2.500
- μ (silicone): 1.000
- μ (membrane): see table below
- d joint depth or membrane thickness

For further support ask your Sika FFI Competence Center.

SYSTEM SOLUTIONS

With SikaMembran® system solutions, facades can be protected effectively and fully in line with their requirements, both for curtain walling in glass and for concrete structures.

A secure connection to the structural formwork, yielding durable waterproofing of the joints, is obtained by the quick and easy bonding of the membranes between the envelope fabric and the structure, with the very tolerant and efficient elastic adhesive SikaBond® TF-Plus N.



Adia Building, Abu Dhabi, 2006
Architects Kohn Pedersen Fox Associates PC
Facade Schmidlin AG

	SikaMembran® Outdoor plus	SikaMembran® Outdoor	SikaMembran® Universal	SikaMembran® Strong
Thickness [mm]	0.6	0.6	0.6	1.2
μ-value	5 000	75 000	102 000	66 000
s_d value [m]	3	45	62	79
System adhesives	SikaBond® TF-Plus N, SikaHyflex®-305, SikaHyflex®-220			
Standard widths of 25 m rolls [cm]	10/15/20/25/30/35/40/45/50/140 (other widths are available on request)			
Main applications	Joints between structure and incorporated units, e.g. facade elements, windows, etc. Connecting joints in concrete and brick constructions in ventilated facades			
Approvals	All products comply with EN 13984 (CE marked) and meet fire retardant requirements of EN 13501-1 Class E (under free suspension)			

These figures are intended as a guide and should not be used in preparing specifications.
 For technical information about the products, please ask for the latest respective data sheets.

SikaTack®-Panel SYSTEM

Rain Screen Cladding With Elegance and Durability

RAINSCREEN CLADDING

Rain can be forced through the joints and openings of a typical building facade through the action of wind or via external and internal pressure differences. Ventilated rainscreen cladding overcomes these potential problems by utilizing the phenomena of pressure equalization. The principle of pressure equalization offered by a rainscreen cladding system ensures the weather tightness of the building structure by eliminating the methods of which rain may enter the facade.

Rainscreen cladding is a tried and tested concept backed up with many years' experience in the development of relatively easily installed lightweight systems that are currently available. The main benefits of a fully integrated rainscreen cladding system for both new build and refurbishment include:

- Aesthetic improvement of the building facade with a wide choice of external finishes available
- Building structure protected from weathering yet remaining vapor permeable
- Increased thermal performance
- Extremely cost effective
- Ease of construction with none of the inconvenience associated with 'wet' render trades

THE SikaTack®-Panel STRUCTURAL FIXING SYSTEM

With SikaTack®-Panel adhesive system cladding finishes can be fixed to a carrier frame and allows the designer the freedom to design facades without any unsightly fixings. The permanent elastic nature of our SikaTack®-Panel adhesive system combined with a tenacious adhesion to a variety of panel substrate types accommodates the natural differential movements of varying building materials for the life of most panel types. This ingenious and simple system offers both the designer and installer alike many advantages over comparable rigid mechanical secret fixing systems. SikaTack®-Panel adhesive system is suitable for the fixing of composites, ceramic, high pressure laminate, cement based cladding panels as well as most metal and powder coated substrates.

Besides appropriate surface pretreatment agents SikaTack®-Panel system comprises of SikaTack®-Panel adhesives and SikaTack®-Panel fixing tape. The double sided adhesive tape is used for the temporary support for cladding panels while the SikaTack®-Panel adhesive cures. SikaTack®-Panel adhesive is moisture-curing single component polyurethane resin based adhesive, capable of withstanding extreme dynamic loads and climatic conditions. Once cured the adhesive remains permanently elastic to accommodate differing thermal expansion of various building substrates. It eliminates stress fatigue at corners of panels and prevents cold bridging.

For calculations of the glue line, depending on the weight of panels, maximal wind load and temperature difference, please contact your Sika FFI Competence Center.



Threshold Residence, Parsons Green
Architects Allford Hall Monaghan Morris
Facade Cladding UK

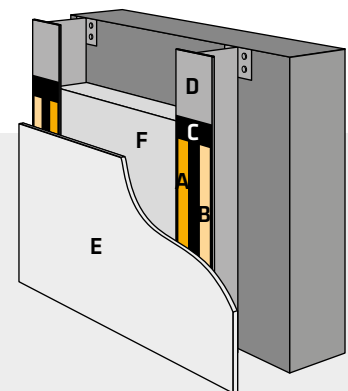

- A SikaTack® Panel Adhesive
- B SikaTack® Panel Prefixing Tape
- C SikaTack® Panel Primer
- D Aluminum Rail System
- E Facade Panel
- F Insulation Material (e.g. mineral wool)

SikaDamp®

Noise Reduction in Panel Walls

With SikaDamp®-620 Sika transfers a well acknowledged noise reduction technology from the car and ship industry to construction sites and provides an easy-to-apply solution to reduce structure-borne vibrations or external impacts (rain drops and hail grains) on thin metal and composite panels in curtain wall spandrel areas or fully cladded rainscreen walls (see page 38).

SikaDamp®-620 elastomer rolls are equipped with a thin aluminum fl ashing and can be easily cut into any customized shapes and sizes. It is firmly rolled on the substrates and demonstrate excellent adhesion to many metal substrates, e.g. galvanized steel, and many organic panel coatings and composite materials. Its outstanding adhesive performance allows it to keep its position in demanding vertical and inverted applications, even at elevated temperatures up to 90 °C. SikaDamp®-620 maintains its acoustic and adhesive properties after subjection to the various accelerated aging and weathering test conditions. For sprayable solutions ask your Sika contact.



Office Building Zurich West, Zurich, 2013
Facade Yuanda Europe

SikaDamp® TYPICAL APPLICATION IN CLADDING WALLS

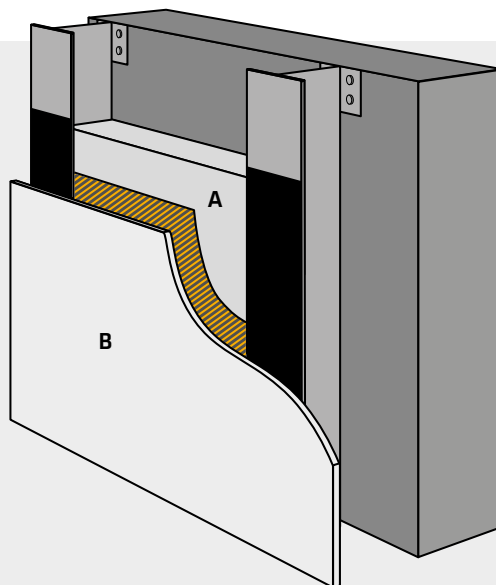

- A** SikaDamp® Sound Damping Sheet
- B** Metal or composite panel

VIBRATION-DAMPING PROPERTIES (ASTM E756)

Loss factor Beam 200 [Hz]

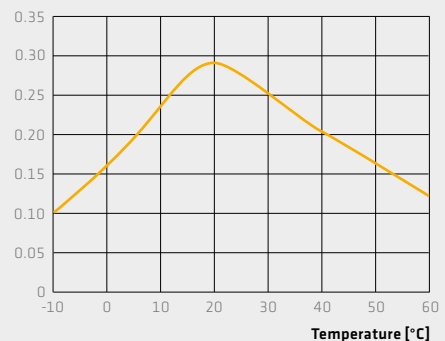

SikaDamp®-620 demonstrates its sound reduction performance over a wide range of temperatures.

SikaGlaze® GG GLASS GROUT

Stress-free Glass Embedding



Glass balustrades should be fixed to the floor with the lowest possible stress to the glass pane. But mechanical fixings transfer high punctual stress to the glass, leading to thicker panes.

An easy-to-apply solution is the embedding of the bottom glass edge in the floor with self-leveling, high-strength fast-curing 2-part PU system SikaGlaze® GG-735, resulting in uniform stress distribution and an enormous reduction of punctual stresses. For a fast, self-leveling application a gap of 10 mm on each glass side is required, leading to a minimum consumption of 2.5 liter per running meter glass balustrade.

SikaGlaze® GG-735 is compatible with many grades of interlayers (e.g. PVB, Ionomers) avoiding delamination, discoloration and glass cracks. In outdoor applications the PU grout shall be protected against weathering with Sikasil® WS-605 S or SikaHyflex®-305 weather sealants.

TESTED AGAINST GERMAN TRAV

SikaGlaze® GG-735 has been tested by the Laboratory for Steel and Light Metal Construction, Munich, for accident proofing based on the Technical Regulations for the use of accident-proof glazing (German abbr. TRAV) and carries a German General Building Authority Test Report. The approval covers a set-up made of two 10 mm tempered or heat strengthened safety glass panes with 1.52 mm PVB interlayer. The clamping depth of the glass pane was 100 mm. The U-channel was made of 10 mm steel and totally rigid in order to test worst case scenario. Impact tests were carried out with a pendulum according to DIN EN 12600 with a dropping height of 700 mm.

60 Threadneedle Street, London, 2007
Architects Fletcher Priest Architects; Facade Josef Gartner

SikaGlaze® GG TYPICAL APPLICATIONS

- A SikaGlaze® GG Glass Grout
- B SikaHyflex® weather sealant
- C Glass balustrade
- D U channel (metal or concrete)

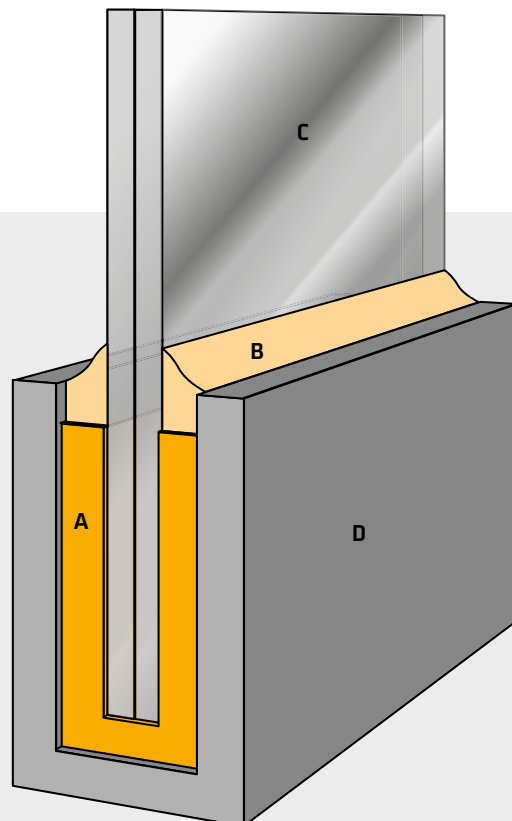

Fast and stress free-embedding of curved balustrades

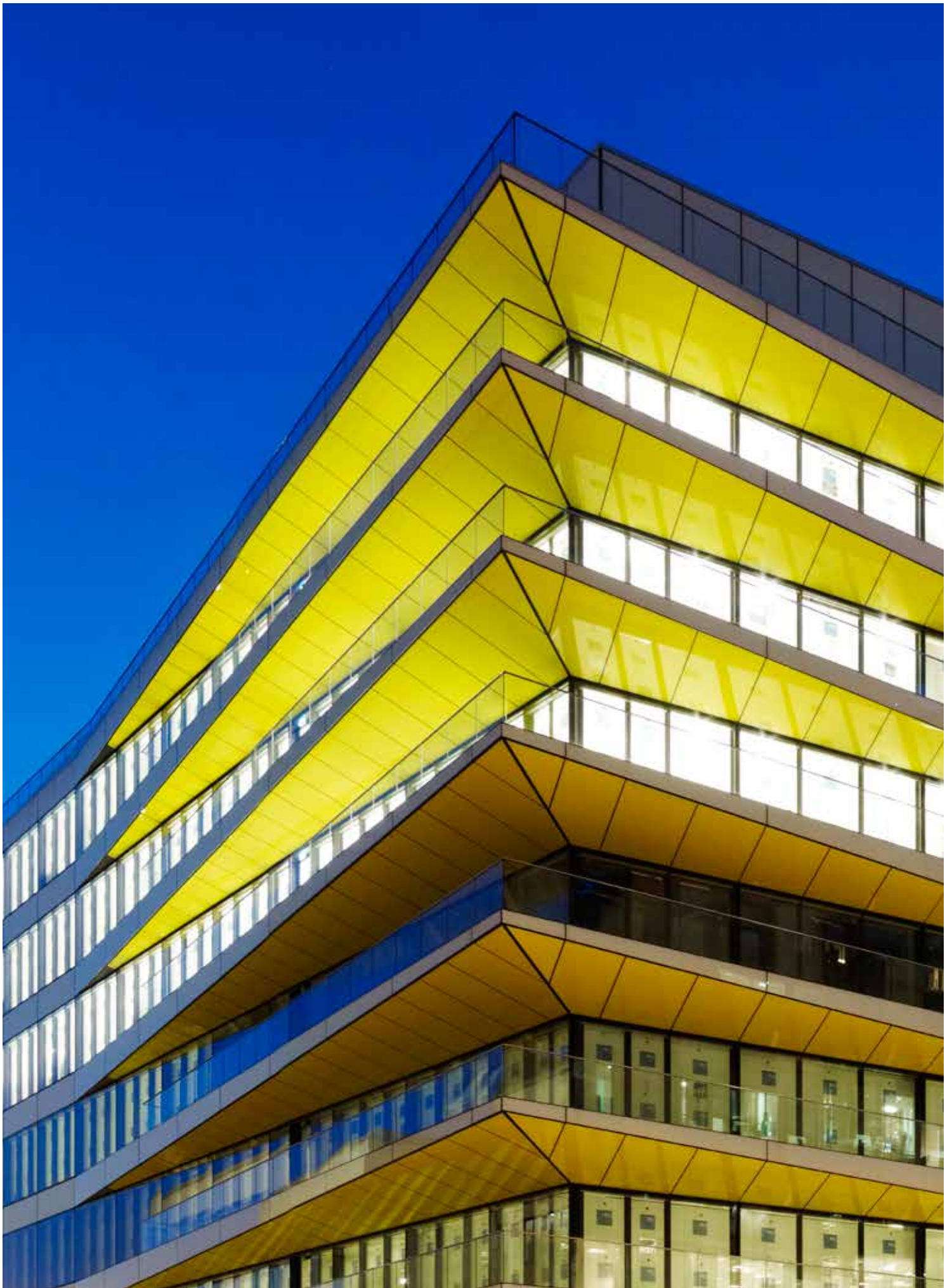

Riverbank House, London, 2011
Architects David Walker Architects; Facade and balustrades Josef Gartner

PROJECT SERVICE

Safety Down to the Last Details

R&D HAS ALWAYS TAKEN PRIDE OF PLACE AT SIKA. At our FFI Competence Centers we combine R&D with a very special service: individualized structural glazing project service and support. This project service is Sika's response to increasing distinctiveness of the buildings and facade projects. Innovative uses of new silicone sealants for facades and windows are in demand; but there is also a growing need for technical support in project planning and execution.

SIKA FFI COMPETENCE CENTERS

At our FFI Competence Centers we develop new products and processing technologies, test known structural glazing methods, and use the results to optimize our technical service and project service. The specialists at our technical Competence Centers provide project service and support for structural glazing projects on all continents – from planning through to execution. We place great importance on interdisciplinary cooperation with our partners in the glass industry and with curtain wall manufacturers.

OUR SERVICE

- Individualized technical service and support with new designs
- Complete structural glazing system tests including joint design, joint dimensioning, adhesion and compatibility tests with original materials
- Support with performing external tests
- Applicator training at the FFI Competence Centers and in the applicators' factory: Production of double glazing units with silicone secondary edge seals, structural bonding with Sikasil® SG silicone
- Practical assistance with all processing problems on site by specially trained engineers
- Development of complete ready-to-install solutions for integrated structural glazing systems and difficult processing conditions
- Development of new products in association with the customer
- After testing and approval of the project guarantee for the adhesion of Sikasil® silicone sealants

SIKA FFI COMPETENCE CENTERS

Global FCC

- **Switzerland**

Regional Technical Centers

- **Germany**
- **Poland**
- **Romania**
- **UK**
- **Dubai**
- **USA**
- **China**
- **Malaysia**

Additionally many local Sika laboratories perform project tests

SYSTEMATIC PROJECT WORKFLOW

Each structural glazing project is individually tested and approved at our FFI Competence Centers. The customer usually receives design approval and information for joint dimensioning within three working days and the lab report within the time listed in the table on page 45. Work can then begin on bonding the elements. Sika gives a guarantee on tested and approved projects.

SYSTEMATIC PROJECT WORKFLOW

DETAILED PROJECT STAGES

Individual project testing is carried out according to a reliable and practicable system, which forms a solid basis for successful project execution.

Note: Detailed information and descriptions of the practical activities, such as cleaning and priming the surfaces or applying the sealants, can be found in the “structural glazing application guidelines”. The forms used for the various stages are available from our homepage www.sika.com/ses.

	Action	Form	Performed by
Design Phase			
Step 1	Project manager (customer) or responsible Sika persons send all relevant design details (drawings – including bonding situation) and project details (wind loads, max. temperatures, glass/panel sizes) to Sika for inspection.	Project information form	Customer
Step 2	Sika performs following items: - checks joint details - checks joint dimensions - assesses the materials used - recommends the correct sealant for these applications based on all the details known	Design assessment	Sika
Test Phase			
Step 3	Customer sends all substrates and ancillary materials to Sika for testing. The number and sizes of the samples are described in the leaflet “Sample Submittal Information”.	Sample submission form	Customer
Step 4	Sika conducts the following tests: - Adhesion tests to all substrates (glass, facade panels and frame materials). - Compatibility tests with all materials (according to customer information) that our adhesives and sealants come into contact with. - Based on the results, Sika makes recommendations for cleaning and, if necessary, priming the surfaces. The results and recommendations are summarized in a laboratory report. A guarantee can only be given if all submitted samples are compatible and the adhesion is sufficient.	Lab report	Sika
Application Phase			
Step 5	Sika instructs the applicator on all matters of the applications: - Adhesive application - Quality control during application - Help with machine application Sika also helps with the correct application of its products (e.g. weather-sealing) on site. After successful instruction, the customer receives a training certificate from Sika.		Sika
Step 6	The customer applies the Sika products as instructed and diligently carries out the recommended quality controls during processing. The quality control is documented on the appropriate forms.	Quality control	Customer
Guarantee Phase			
Step 7	Once application of the products is complete, the customer sends all QC documents to Sika for inspection		Customer
Step 8	Sika provides a limited guarantee on Sika products. For details please ask the local Sika sales manager	Templates are available on request	Sika

TRIPLE-TESTED QUALITY

1. Sealant Tests According to Standards and Guidelines

Silicone adhesives used for structural glazing must withstand extreme demands on their load-bearing capacity and durability. Sika offers one- and two-part systems that conform to the European guideline for bonded glass structures (EOTA ETAG No. 002). The specified tests include, for example, UV/ water immersion at 45 °C for 1000 h and exposure to NaCl/moisture and SO₂/ moisture. They also comply with American standards ASTM C920 and C1135, and Chinese standard GB 16776.

2. Quality Control in Silicone Sealant Production

As a company certified to ISO 9001 and ISO 14001, Sika has developed a quality control system that identifies any deficiencies at the production stage, and guarantees that only perfect goods leave the plant. As a prerequisite for the CE marking, Sika's facade silicone production is regularly supervised by external auditing institutions.

3. Quality Control in Sealant Application

For every project, it is essential that the customer should carry out factory production controls, with evidence of the mechanical strength and adhesion to various substrates (see table below). Precise details on the tests can be found in our "structural glazing application guidelines". Sika service laboratories advise customers as to how to perform best these controls and train staff. All QC test specimens must be kept for the full guarantee term.



IMPORTANT

Sikasil® SG adhesives shall only be used for structural projects if Sika has first given written approval for the particular project.

MINIMUM QUALITY CONTROL DURING STRUCTURAL BONDING

Sikasil® SG-18, SG-20

Skin forming time
Tack-free time

Adhesion test on original materials
(glass, support frame)

Measurement of Shore A hardness

Mechanical properties on H-test
specimens according to ISO 8339

Sikasil® SG-500, SG-500 CN, SG-550

Visual control of the mixing quality
(butterfly test or marble test)

Quantitative check of the mixing ratio
by weight

Pot life
Tack-free time

Adhesion test on original materials
(glass, support frame)

Measurement of Shore A hardness

Mechanical properties on H-test
specimens according to ISO 8339

PROJECT TESTS

CHECKING DESIGN DRAWINGS

Our FCCs check joint design and dimensions. This ensures that the anticipated wind loads and different thermal expansions of the substrates are not outside the stressing limits for our silicone adhesives. We subsequently provide technical service in the selection of appropriate silicone sealants for structural glazing, insulating glazing and weatherseals.

ADHESION AND COMPATIBILITY TESTS

Adhesion tests according to national and international guidelines and standards, and our own test methods ensure perfect adhesion of our products to the substrates used in any one project. We also test the compatibility of all materials that come into contact with Sikasil® silicone sealants and adhesives. Only compatible materials ensure that there is no negative effect on either the adhesion behavior or the mechanical properties of the silicone adhesives. The results are provided as a report. We use the results obtained to make recommendations on surface treatment, e.g. cleaning and priming, of the substrates used.

TECHNICAL CUSTOMER SUPPORT

The quality and optical appearance of facades also depend on professional workmanship. We therefore advise our project partners to use Sikasil® SG silicone adhesives and sealants. We will demonstrate how to use them professionally, and help with any practical problems.

IMPORTANT

The samples sent to Sika for project tests (adhesion and compatibility tests like) must be representative for the materials used in the building project. Materials must not be exchanged during the project without notifying Sika.

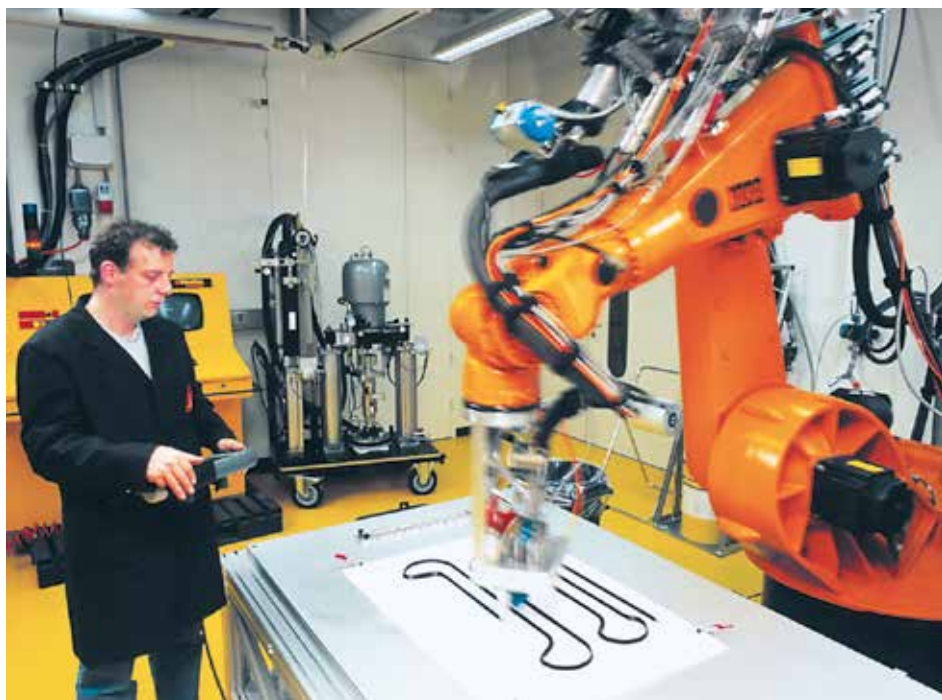

Photo: Application trials at Sika System Engineering

DURATION OF ADHESION AND COMPATIBILITY TESTS

	Duration of Tests, incl. Report
Sikasil® SG Adhesive Sealants Adhesion tests with sealant bead Compatibility test with accessories Compatibility test with laminated safety glass	33 days 33 days 115 days
SikaHyflex® Weather Sealants Adhesion tests with sealant bead Compatibility test with accessories Compatibility test with laminated safety glass	33 days 33 days 115 days
Non-staining Sealant SikaHyflex®-355 Non-staining test	45 days

SUPPORT BEYOND STANDARDS

DESIGN PHASE

FINITE ELEMENT CALCULATIONS

Joint design becomes more complex, joint sizes get smaller and smaller, loads and movements go to extremes.

Our specialists in the FFI Competence Center in Switzerland accompany trends and developments not only with sophisticated tests but also with the latest methods of finite element calculations, both on whole building details, such as the cold bent glass element on the right, and on adhesive joints scrutinizing them for peak stresses with hyperelastic modeling shown below.

Aluminum L-profile

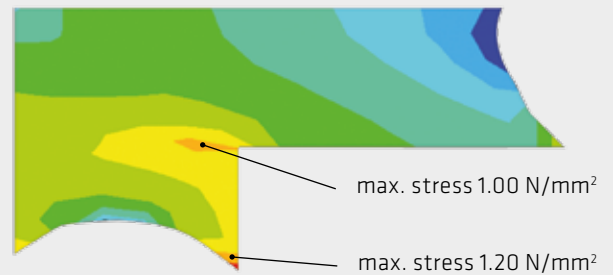
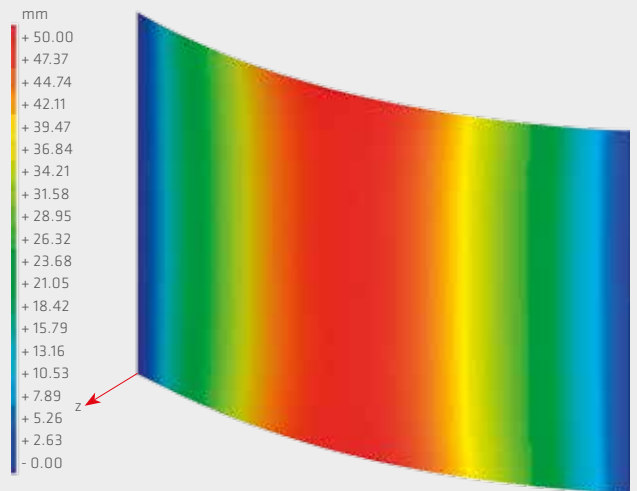
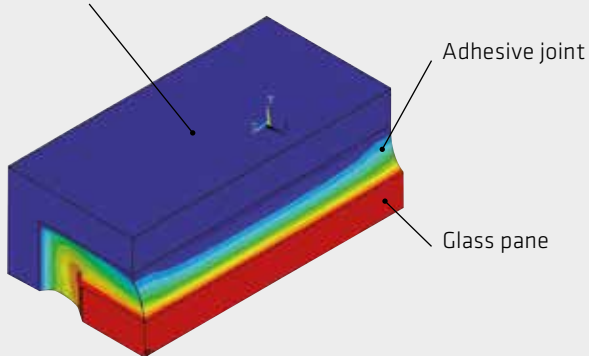

TEST PHASE

With more than 20 years experience in curtain wall industry and structural glazing applications in particular Sika puts enormous efforts in adhesion and compatibility tests before the project start. Regardless of any complexity of test specimens or extreme climatic conditions in the test chambers or even long test durations exceeding standard test methods.



APPLICATION PHASE

Sika Technical Service teams are located around the world, and are dedicated to providing best practice selection, validation and application of Sika materials. By being located close to our customers, Sika's application service provides fast and reliable support throughout the technical application development process to ensure the best possible results - from product development (top left) to small scale manual application (bottom left) to automated series production (right).



Photos: Application trials at sedak GmbH & Co KG

DEMANDING SPECIAL TESTS

HIGH SPEED TESTS FOR BOMB BLAST AND HURRICANE RESISTANCE

For Sika as one of the market leaders in the automotive and transportation industry high-speed tests are state-of-the-art tests at its high-tech laboratories. Before any crash test or bomb blast test we measure high speed impact on sealants and adhesives on small specimens. Based on these values we help to optimize the joint dimensions.

HIGH SPEED LAP SHEAR TESTS

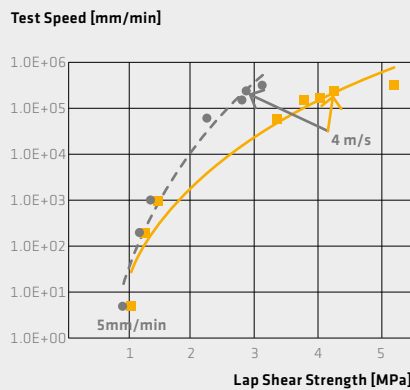

The higher the impact speed, the higher the adhesives' shear strength, the higher the design stress.



Impact test machine with pendulum (ISO 11343) for velocities of 1 m/s to 5 m/s at temperatures from -50 to 80 °C. As glass deforms with a max. speed of 4 m/s, this is the optimal range for simulating bomb blast tests.

GLOBAL BUT LOCAL PARTNERSHIP



FOR MORE INFORMATION:

For more literature about Sika Facade and Fenestration solutions browse:

www.sika.com/ffi-downloads

Find more Sika Projects under:

www.sika.com/ffi-projects

WHO WE ARE

Sika is a specialty chemicals company with a leading position in the development and production of systems and products for bonding, sealing, damping, reinforcing and protecting in the building sector and the motor vehicle industry. Sika has subsidiaries in 93 countries around the world and manufactures in over 170 factories. Its more than 17 000 employees generate annual sales of CHF 5,49 billion in 2015.

Technical Service

Sika Services AG
FFI Competence Center
Tueffenwies 16
CH-8048 Zurich
Phone +41 58 436 5633
Fax +41 58 436 5407
it-ses-admin@it.sika.com
www.sika.com/ses

Customer Service

Sika Engineering Silicones Srl.
Via L. Einaudi, 6
I-20068 Peschiera Borromeo (MI)
Phone +39 02 516591 205
Fax +39 02 516591 298
it-ses-admin@it.sika.com

Our most current General Sales Conditions shall apply.
Please consult the Data Sheet prior to any use and processing.



SIKA SERVICES AG
Tueffenwies 16
8048 Zurich
Switzerland



BUILDING TRUST

